

*ELECTRONIC*  
**AVANTCODE**  
*USER GUIDE*

*Version 0.0*

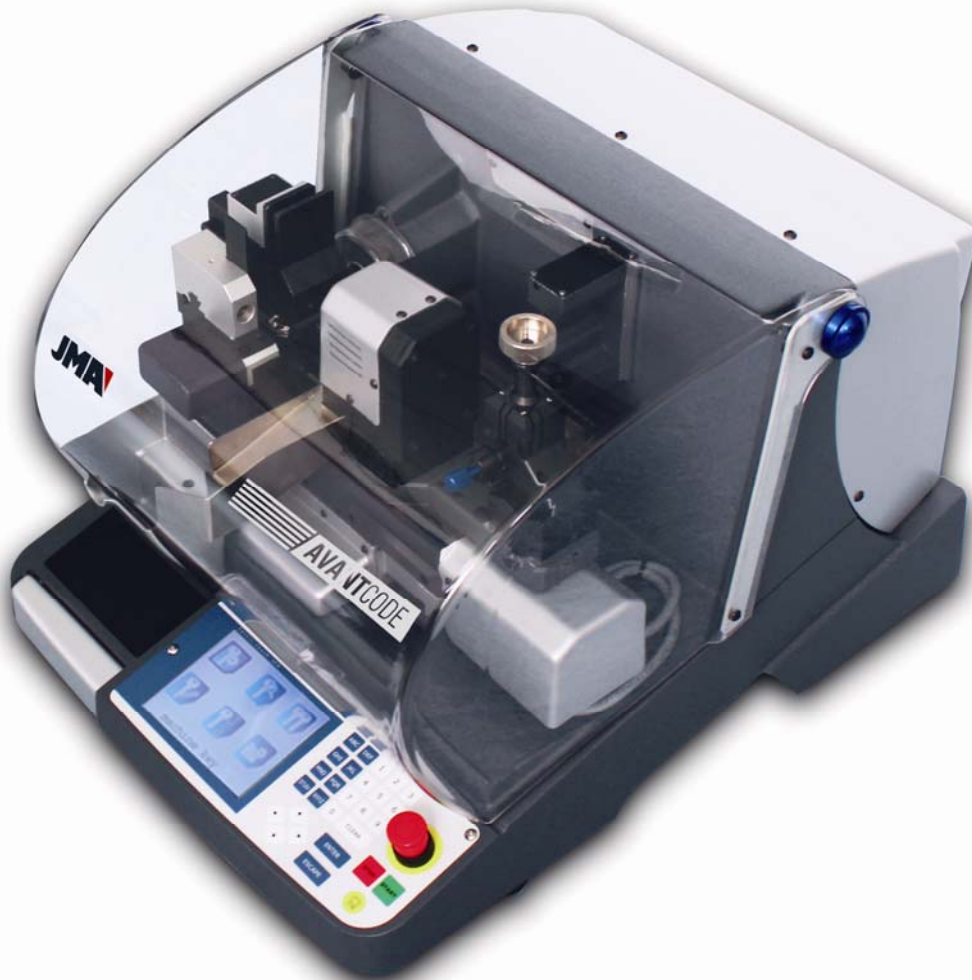

## INDEX:

<b>1</b>	<b>INTRODUCTION AND OVERVIEW</b> .....	<b>1</b>
1.1	OVERVIEW.....	1
1.2	TRANSPORT AND PACKAGING.....	1
1.3	ID LABEL.....	1
<b>2</b>	<b>MACHINE INSTALLATION AND CHARACTERISTICS</b> .....	<b>2</b>
2.1	INSTALLATION.....	2
2.2	DESCRIPTION OF THE MACHINE.....	2
2.3	MAIN CHARACTERISTICS.....	4
2.4	KEY FAMILY.....	5
2.4.1	KEY TERMS.....	5
2.5	MAIN PARTS OF THE MACHINE.....	6
2.5.1	AVANTCODE (STANDARD).....	6
2.5.2	AVANTCODE (KEY FEEDER).....	7
2.6	TECHNICAL INFORMATION.....	8
2.7	MACHINE KEYBOARD AND KEY FUNCTION.....	9
2.8	CUTTING WITH ELECTRICITY.....	10
2.8.1	IMPROPER USE OF ELECTRICITY.....	10
2.9	TYPES OF CUT.....	11
2.10	ACCESORIES.....	12
<b>3</b>	<b>CONFIGURATIONS AND USE</b> .....	<b>13</b>
3.1	AVANTCODE (STANDARD).....	14
3.1.1	USING THE "MP1" STANDARD CLAMP.....	14
3.1.2	CUTTING CROSS KEYS.....	16
3.1.3	MOUNTING AND DISMOUNTING THE CLAMP.....	17
3.2	AVANTCODE (KEY FEEDER).....	18
3.2.1	USING THE AUTOMATIC CLAMP.....	18
3.2.2	USING THE FEEDER.....	19
3.2.3	ASSEMBLY AND DISASSEMBLY OF THE AUTOMATIC CLAMP & FEEDER.....	20
3.3	CONVERT THE AVANTCODE (STANDARD) INTO AN AVANTCODE (KEY FEEDER).....	22
<b>4</b>	<b>OPERATION MANUAL</b> .....	<b>23</b>
4.1	CUT KEY.....	24
<b>4.2</b>	<b>READ FILE</b> .....	<b>33</b>
4.4	EDIT FILE.....	40
4.4.1	CREATE FILE.....	40
4.4.2	MODIFY FILE.....	44
4.4.3	DELETE FILE.....	45
4.5	CONFIGURATION.....	45
4.6	MAINTENANCE.....	50
4.6.1	Manufacturer values.....	50
4.6.2	Data connection.....	50
4.6.3	Information.....	50
4.6.4	Speed.....	50
4.6.5	Password.....	50
4.6.6	Other options.....	51
4.7	PC OPERATION.....	53
<b>5</b>	<b>CLEANING AND SAFETY</b> .....	<b>54</b>
<b>6</b>	<b>MAINTENANCE</b> .....	<b>54</b>

6.1	LOCATING MALFUNCTIONS.....	55
6.2	REPLACING THE FUSES.....	56
6.3	REPLACING AND TENSING THE BELT.....	57
6.4	REPLACING THE AUTOMATIC CLAMP SET.....	58
6.5	REPLACING THE MILLING TOOL.....	58
6.6	REPLACING THE CARRIAGE SENSOR.....	59
6.6.1	X AXIS.....	59
6.6.2	Y AXIS.....	59
6.7	REPLACING THE MOTOR.....	61
6.8	REPLACING THE KEYBOARD.....	61
6.9	REPLACING THE LEDS.....	62
<b>7</b>	<b>WASTE DISPOSAL.....</b>	<b>63</b>
7.1	PACKAGING.....	63
7.2	SHAVINGS.....	63
7.3	MACHINE.....	64
<b>8</b>	<b>SUPPORT.....</b>	<b>64</b>
<b>9</b>	<b>CONSTITUENT PARTS.....</b>	<b>64</b>

# 1 INTRODUCTION AND OVERVIEW

## 1.1 OVERVIEW

The AVANTCODE key cutting machine has been designed in compliance with EU safety regulations.

The safety of users of this type of machine is only achieved thanks to a well designed safety program, the implementation of a maintenance program and by following the recommendations for use, and complying with the safety rules set out in this manual.

Although this machine is not hard to install, it's advisable not to install, adjust or handle it without having first read this manual.

The machine leaves our factory ready to use and only needs to be calibrated for the type of operations for which it will be used.

## 1.2 TRANSPORT AND PACKAGING

The machine comes inside packaging with the following measurements:

Width = 640 mm, length = 770 mm, height = 575 mm

Machine weight including packaging = 60 kg.

Inspect the machine carefully on opening the parcel to ensure that no damage occurred during transport. If there is an anomaly, please contact the transport company immediately and do not use the machine until they have carried out their inspection.

## 1.3 ID LABEL

The AVANTCODE duplication machine has an ID label (Fig. 1) showing the serial number or machine registration number as well as the manufacturer's name and address, EC label and year of manufacture.



Fig.1

## 2 MACHINE INSTALLATION AND CHARACTERISTICS

### 2.1 INSTALLATION

The machine has been assembled, calibrated and checked and is ready to use. There is no need to perform any assembly operations. However, before using the machine, it's a good idea to carry out the following checks:

- Connect the AVANTCODE machine to a suitable power supply (220 V 50/60 Hz), in accordance with the information specified on the ID label on the back of the machine.
- It is very important that the electricity supply is earthed. Ensure that the machine is connected to the earth.

After unpacking the machine and connecting the power supply, move the switch to position 1. (Fig.2).



Fig.2

Make sure the emergency button is not pressed down, if it is, release it. When switched on, the JMA logo will appear alongside an internal test, then a few moments later, the carriages will move to their start-up position (if not in position already). The machine is ready to use.

### 2.2 DESCRIPTION OF THE MACHINE

The AVANTCODE machine has been designed to cut flat keys. The tiniest details have been carefully designed to produce a compact machine that's easy to use and very precise. This is a mechatronic machine, with two stepper motors for moving the carriages and a third motor to open the automatic clamp (with key feeder).

One of the machine's principle characteristics is that it allows you to use 2 different configurations without having to implement major changes. These two options are as follows:

**AVANTCODE (STANDARD):** Standard clamp with 4 faces

**AVANTCODE (KEY FEEDER):** Automatic clamp and key feeder for automatically cutting keys.

This is a versatile machine that can be used both with standard clamps or the key feeder.

# 1 INTRODUCTION AND OVERVIEW

## 1.1 OVERVIEW

*The AVANTCODE key cutting machine has been designed in compliance with EU safety regulations.*

*The safety of users of this type of machine is only achieved thanks to a well designed safety program, the implementation of a maintenance program and by following the recommendations for use, and complying with the safety rules set out in this manual.*

*Although this machine is not hard to install, it's advisable not to install, adjust or handle it without having first read this manual.*

*The machine leaves our factory ready to use and only needs to be calibrated for the type of operations for which it will be used.*

## 1.2 TRANSPORT AND PACKAGING

*The machine comes inside packaging with the following measurements:*

*Width = 640 mm, length = 770 mm, height = 575 mm*

*Machine weight including packaging = 60 kg.*

*Inspect the machine carefully on opening the parcel to ensure that no damage occurred during transport. If there is an anomaly, please contact the transport company immediately and do not use the machine until they have carried out their inspection.*

## 1.3 ID LABEL

*The AVANTCODE duplication machine has an ID label (Fig. 1) showing the serial number or machine registration number as well as the manufacturer's name and address, EC label and year of manufacture.*



Fig.1

## 2 MACHINE INSTALLATION AND CHARACTERISTICS

### 2.1 INSTALLATION

The machine has been assembled, calibrated and checked and is ready to use. There is no need to perform any assembly operations. However, before using the machine, it's a good idea to carry out the following checks:

- Connect the AVANTCODE machine to a suitable power supply (220 V 50/60 Hz), in accordance with the information specified on the ID label on the back of the machine.
- It is very important that the electricity supply is earthed. Ensure that the machine is connected to the earth.

After unpacking the machine and connecting the power supply, move the switch to position 1. (Fig.2).



Fig.2

Make sure the emergency button is not pressed down, if it is, release it.

When switched on, the JMA logo will appear alongside an internal test, then a few moments later, the carriages will move to their start-up position (if not in position already). The machine is ready to use.

### 2.2 DESCRIPTION OF THE MACHINE

The AVANTCODE machine has been designed to cut flat keys. The tiniest details have been carefully designed to produce a compact machine that's easy to use and very precise. This is a mechatronic machine, with two stepper motors for moving the carriages and a third motor to open the automatic clamp (with key feeder).

One of the machine's principle characteristics is that it allows you to use 2 different configurations without having to implement major changes. These two options are as follows:

**AVANTCODE (STANDARD):** Standard clamp with 4 faces

**AVANTCODE (KEY FEEDER):** Automatic clamp and key feeder for automatically cutting keys.

This is a versatile machine that can be used both with standard clamps or the key feeder.

*The AVANTCODE machine, gives you the following options:*

*A database containing the key codes for locks, vehicles, etc. Flat keys in general. This gives you tremendous flexibility and speed when cutting keys.*

*Connect the AVANTCODE to a compatible Intel PC with the Interactive Key Software (IKS) installed. This program is a database containing key codes, identical to the machine's database. It provides a completely integrated working system (code search, selection of the bittings to cut, additional information about the lock, complete digital JMA key catalogue, etc.)*

*Use the AVANTCODE to create your own keys using the laser reader that comes included in the machine. Create and save your own new keys or enter the latest keys on the market into the machine without having to wait for the database to be updated.*

*Use AVANTCODE to reproduce any type of flat key using the laser system.*

*Read the key code of a known key. Correct any cutting errors resulting from a variety of reasons such as key wear, modification of the key data, etc.*

## **2.3 MAIN CHARACTERISTICS**

*The main characteristics are described below:*

- *Movements*

*The 2 axes are moved using precision spindles that are activated by stepper motors on roller guides.*

- *Standard clamp*

*Standard 4-sided clamp designed to grip almost all flat key models.*

- *Tool*

*Easy to replace, widia milling tool, with suitable resistance and cutting capabilities for this type of work and rotation speed.*

- *Display screen*

*Located on the front of the machine, with an LCD Touch Screen measuring 5.7".*

- *Laser reader*

*Laser for reading all keys to be copied.*

### **KEY FEEDER**

- *Automatic clamp. (section. 3.2.1)*
- *Loading unit. (section 3.2.1)*

## 2.4 KEY FAMILY

The AVANTCODE machine copies the following types of keys:

- Flat keys.
- Car keys.
- FORD, ABLOY and MAILBOX keys.

### 2.4.1 KEY TERMS

Diagram of a key showing the principle parts. (Fig.3)

1. Bow
2. Collar
3. Upper stop
4. Lower stop
5. Bittings
6. Blade
7. Back
8. Tip

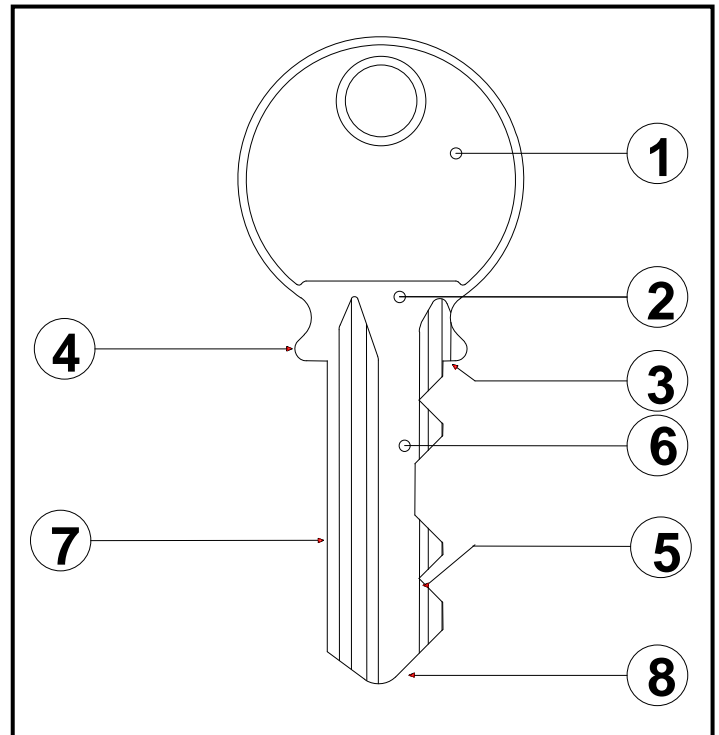
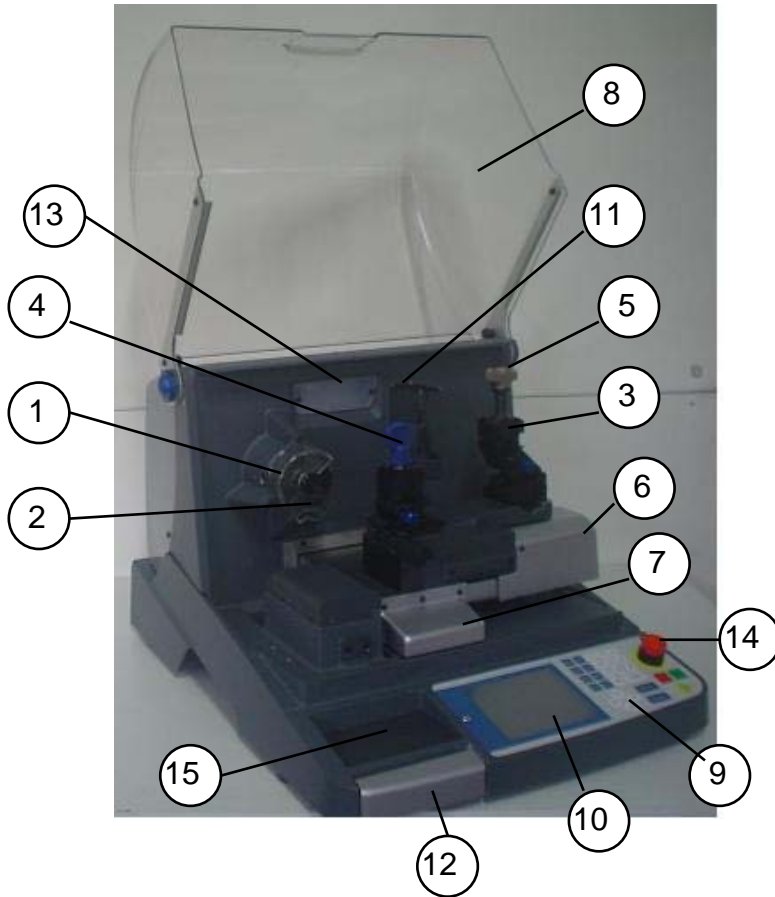

Fig.3

## 2.5 MAIN PARTS OF THE MACHINE

### 2.5.1 AVANTCODE (STANDARD)



1. Milling tool.
2. Mill protector
3. Standard clamp (MP1).
4. Mechanized clamp lever.
5. Clamp reading lever.
6. X carriage.
7. Y carriage.
8. Protective shield.
9. Keyboard.
10. Display screen.
11. Laser reader.
12. Shavings box.
13. Light.
14. Emergency button.
15. Mat.
16. Serial line cable (RS-232).
17. Socket.
18. On/off switch.
19. USB.
20. Ethernet.

Fig.4

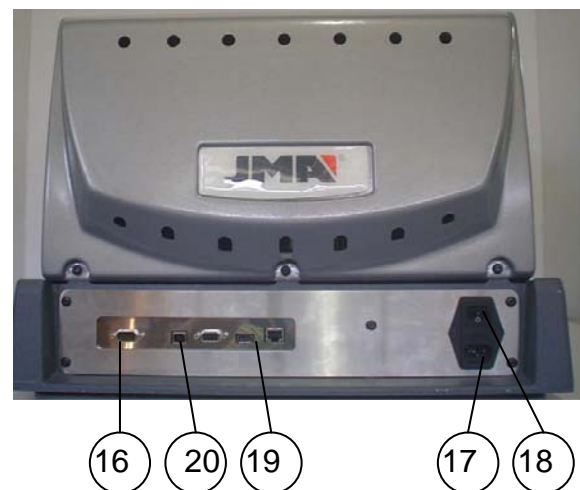

2.5.2 AVANTCODE (KEY FEEDER)

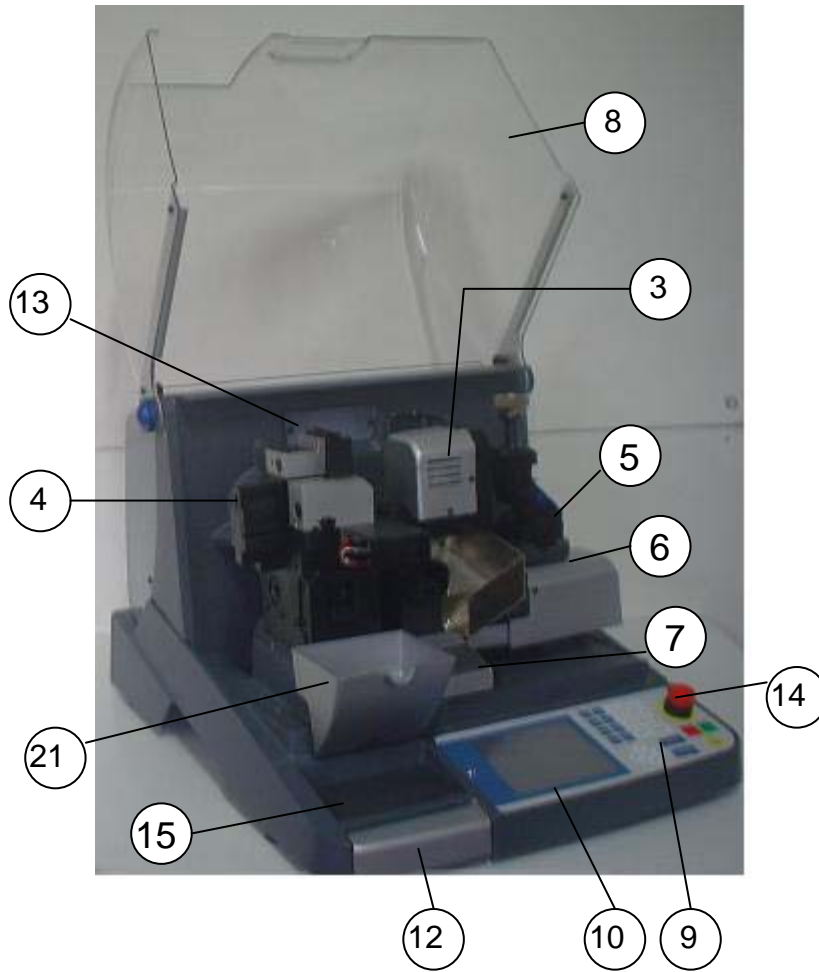

1. Milling Tool.(Fig.4).
2. Mill protector. (Fig.4)
3. Automatic clamp.
4. Loading unit.
5. Reader clamp.
6. X carriage.
7. Y carriage.
8. Protective shield.
9. Keyboard.
10. Display screen.
11. Laser reader. (Fig.4)
12. Shavings box.
13. Light.
14. Emergency button.
15. Mat.
16. Serial line cable (RS-232).
17. Socket.
18. On/off switch.
19. USB.
20. Ethernet
21. Key box.

Fig.5

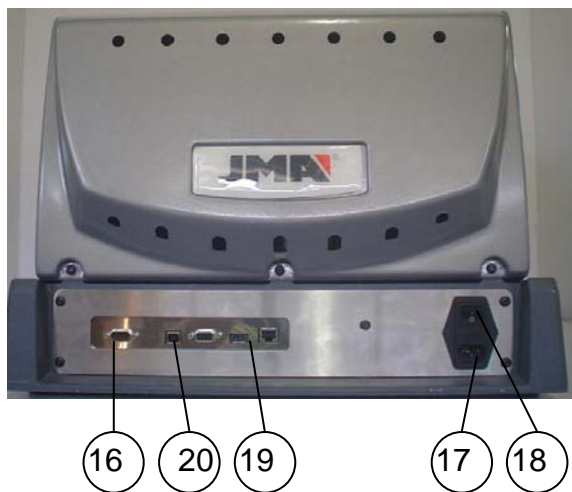

## 2.6 TECHNICAL INFORMATION

The main technical information is set out below:

Motor.....Single phase 220V, 50 Hz, 0.25 Kw, 3000 rpm, 2.04 Amp.

Milling.....Widia  $\varnothing$  70 x 16 x 5.25 mm.

Speed..... 1500 rpm.

Clamps..... Four faced.

Movement..... Via ball spindles activated by stepper motors on roller guides.

Strokes..... X= 40 mm.  
Y= 100 mm.

Light..... LED

Dimensions..... Depth: 650 mm, Width: 495 mm, Height: 420 mm.

Display screen..... 5.7" LCD Touch Screen.

Weight..... 55 kg

### CLASS 1 LASER DEVICE

- Maximum radiation excluding safety block: 200  $\mu$ W
- Wavelength: 780 nm (not visible)
- Classified according to: EN 60825-1:1994 + E.C. 1995 + A1:2002 + A2:2001

## 2.7 MACHINE KEYBOARD AND KEY FUNCTION

The machine keyboard basically comprises a Touch Screen LCD, with some raised keys for correct use and an emergency button. The touch screen only uses icons and the raised keys are used in all of the various screens (Fig. 6)

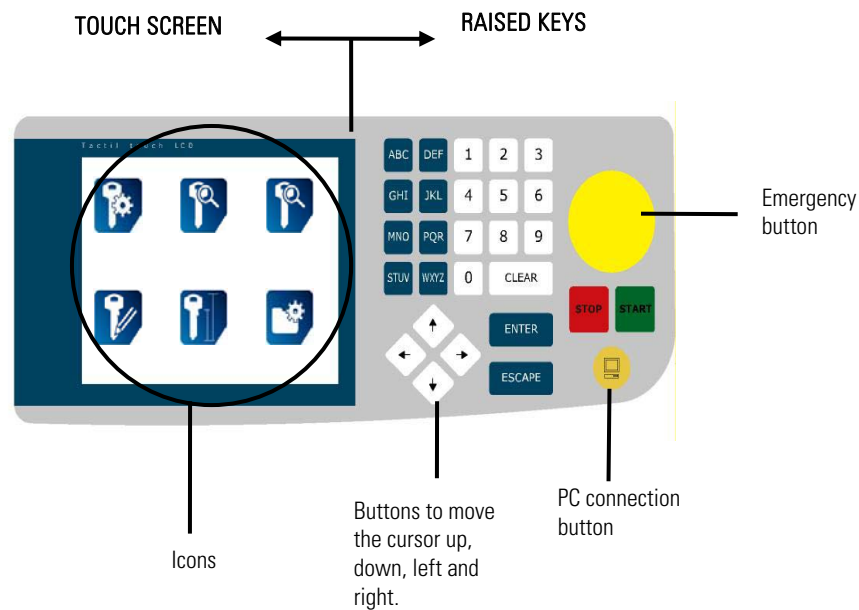

Fig.6

- **ENTER** This is a confirmation key. It's the equivalent of 'RETURN' on a computer, used to confirm the on-screen option and continue to the next menu, to save the information from the keyboard and the computer.
- **ESCAPE** Cancel button, cancels the text on the screen, can also be used to exit a previous menu or return to the main menu.
- **START** Used to start the cutting operations and, if the cycle has stopped, to re-start it.
- **STOP** Used to stop cutting operations.
- **CLEAR** Used to delete the characters entered on screen.



The alphanumeric keys are used as follows:

- Each number has its own key.
- The letter keys work as follows:
  1. To select the first letter, simply press it once.
  2. Select the second letter on the keyboard by pressing the same key twice.
  3. Select the third letter on the keyboard by pressing the same key three times. If you press the same letter more than three times, it will go back to the first letter and so on.

## 2.8 CUTTING WITH ELECTRICITY

The machine comes equipped with a low current that enables numerous improvements when cutting keys (Fig.7), such as:

- a) Placing the key in the best clamp face (1, 2, 3, 4) to ensure a better grip.
- b) Avoiding the need for pins and/or adaptors.

When the electricity is switched on, the cutting depth is automatically calculated once the key is touched. Electricity can be used with steel, brass and zamak keys.

To activate the electricity, go to the final screen of the cutting menu, under the electricity section and then press the START button (Fig.8)

**Electric contact**

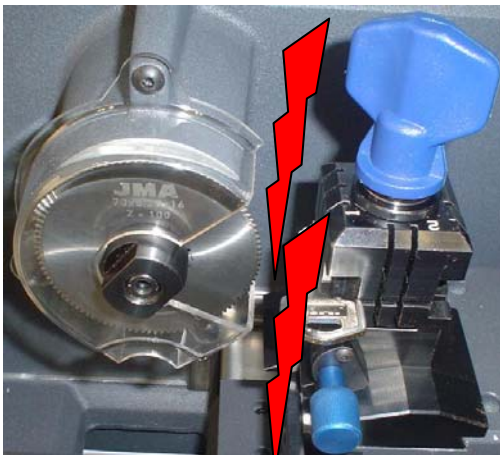

Fig.7

<b>CUT KEY</b>
Cut key
New bittings
Number of keys
Cut - electricity
Type of cut - NORMAL
Material: Steel-Nickel Silver

Fig.8

### 2.8.1 IMPROPER USE OF ELECTRICITY

Do NOT cut anodized aluminum, plastic or other non-conductive materials.

## 2.9 TYPES OF CUT

The machine can cut 3 different types - normal, ideal and flat. This option appears on the various machine options - cut key, read key, copy key, edit key (see section 4.1). The cutting option is in the last screen in the cutting window (Fig.9).

<b>CUT KEY</b>
Cut key
New bittings
Number of keys
Cut - electricity
Type of cut NORMAL
Material: Steel-Nickel Silver

Fig.9

CUT TYPES:



Normal: For standard vehicle and lock keys.



Ideal: This is the most innovative vehicle key - the join between the bitting angles is automatically calculated by the AVANTCODE machine, to achieve variable angle combinations. This makes it easier to move the key and prolongs the life of the lock.



Flat: Used particularly in vehicle keys, where bitting edges are eliminated to make it easier to move the pins or covering when the key is inserted in the lock.

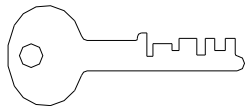

Vertical: Used in special mailbox keys, for example Ford, Abloy, etc. A special milling tool is required.

Radial: Used to produce a round between the base and the exit angle of the key.

## 2.10 ACCESORIES

The AVANTCODE machine comes with a box of accessories for maintenance and repairs (Fig.10). The following accessories are included::







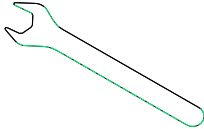

<p>18 mm spanner</p> 	<p>2 mm Allen key</p> 	<p>Fuse: T4A 250V</p> 
<p>Mill blocking bar</p> 	<p>2.5 mm Allen key</p> 	<p>Stylus Touch scream</p> 
<p>Brush</p> 	<p>3mm T-shaped Allen key</p> 	<p>USB</p> 
<p>Set of tip stops</p> 	<p>4mm Allen key</p> 	
<p>Set of II tip stops</p> 	<p>5mm Allen key</p> 	
<p>Set of III tip stops</p> 	<p>Calibration template</p> 	

Fig.10

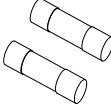
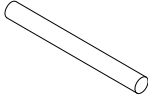
### 3 CONFIGURATIONS AND USE

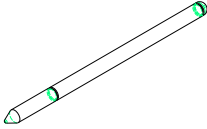
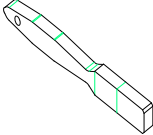
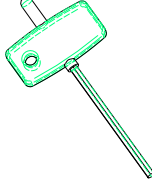
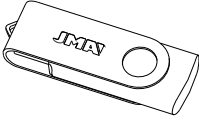
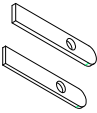
The AVANTCODE machine can have two separate configurations:

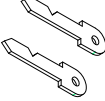
1. AVANTCODE (STANDARD): Clamp and reading clamps (Fig.11)

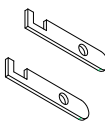
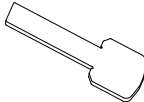
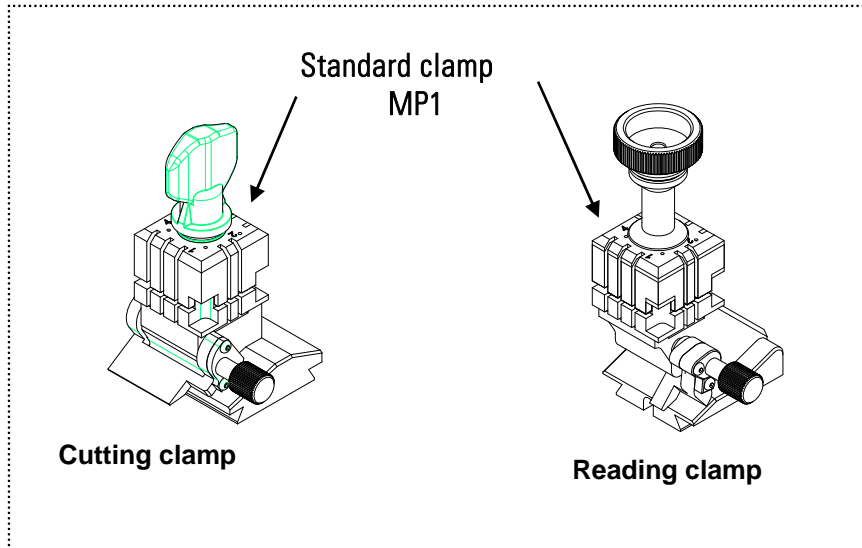

Fig.11

2. AVANTCODE (KEY FEEDER): Automatic and loading clamp and reading clamp (Fig.12)

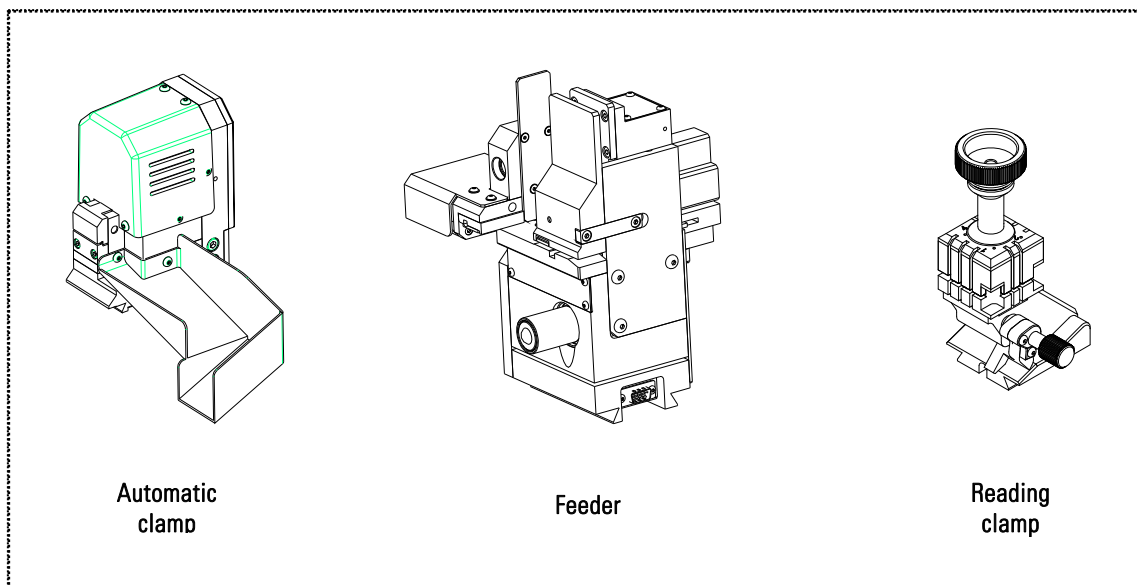

Fig.12

### 3.1 AVANTCODE (STANDARD)

#### 3.1.1 USING THE "MP1" STANDARD CLAMP

The machine comprises two clamps, a clamp and a reading clamp. The keyblank to be cut is placed in the clamp and the original key is placed in the reading clamp. The key is fastened in the standard "MP1" clamp designed to hold various key types.

You have to consider two aspects when gripping the key: The side and top of the key.

- Side 1, 2, 3 and 4.

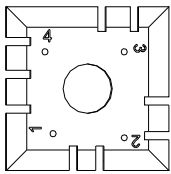

The standard clamp has 4 faces (numbering engraved on the top of the clamp) allowing you to clamp the profile and back of keys. The standard clamp is designed to hold various types of key.

The different sides and characteristics of the key to clamp are described

below:

- Cutting keys supported on the back:
  - Side 1: keys with normal blades.
  - Side 2: keys with narrow blades.
- Cutting keys by clamping the key by its profile:
  - Side 3: Key with guide on the lower part.
  - Side 4: Key with guide on the lower part.

Diagram of the standard model with images of the various clamps (Fig.13).

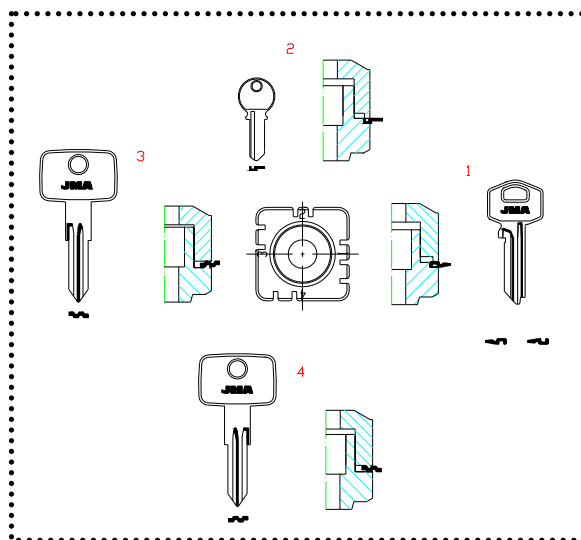
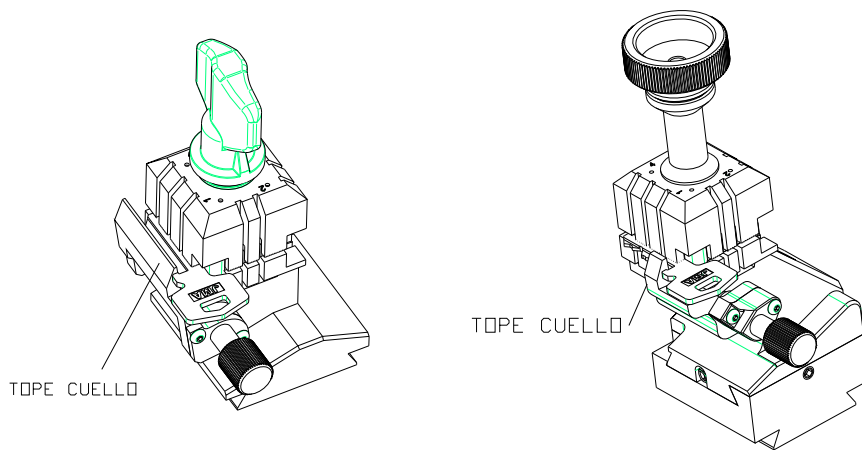

Fig.13

- *Key stop.*

*Once you have selected the side of the clamp, position the key lengthwise, bearing in mind the key stop. There are two types of stop, depending on the key model:*

1. *Collar stop (C): This is the most common type. The key is stopped by mechanically blocking the clamp (Fig.14)*

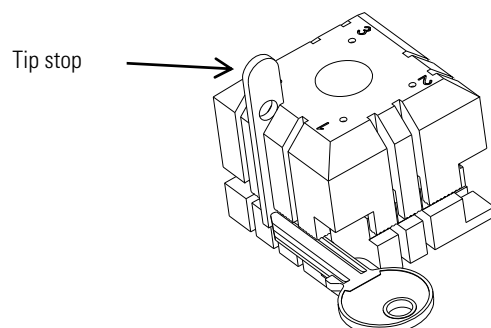

*Fig.14*

2. *Pointed tip (1, 2, 3): The key tip is produced using the tip stop supplied as an accessory, which is placed in the standard clamp slot beside the key.*

*Example of a (Fig.15)*

*key placed in side 1 and tip 2*



*Fig.15*

Image of a clamp showing the slot numbering for producing the tips (Fig.16)

- Side 1: Tips 1, 2, 3.
- Side 2: Tips 1, 2.
- Side 3: Tips 1, 2.
- Side 4: Tips 1, 2.

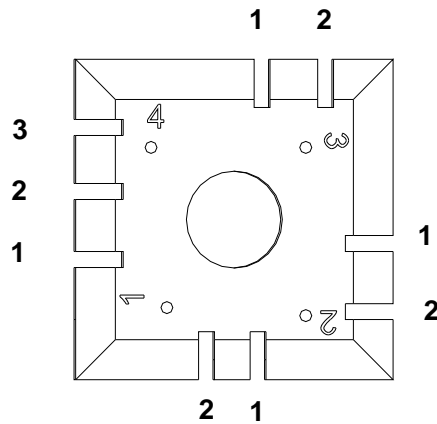

Fig.16

The instructions for correctly clamping the key in the standard clamp are shown in one of the information windows prior to cutting. (Fig.17)

Mechanical information		
	Milling tool	FP16W
	Clamp	MP1
	Clamp side	1
	Clamp stop	C

Fig.17

### 3.1.2 CUTTING CROSS KEYS

- “Side 1” of the clamp must be used to cut this type of key (Fig.18).
- Insert both wedges (X) in the vertical slots (E) of the clamps. Insert them so that the wedge openings face towards the mill or probe.  
(NB: Choose the pairs of wedges in accordance with the length of the key that needs to be cut.)
- Insert the original key in the clamp until the tip rests against the Wedge (X). In this position, grab the key by turning the Clamp Lever (B). Repeat the process for the keyblank.
- Release the carriage and start cutting.  
(NB: This key has three bitted sides. As a result, the same operation must be repeated another two times for the other two bits).

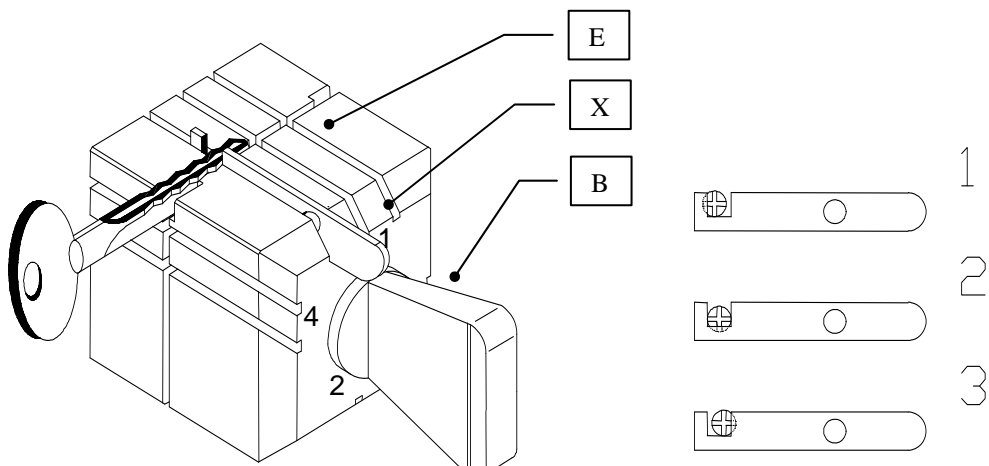

Fig.18

### 3.1.3 MOUNTING AND DISMOUNTING THE CLAMP

- **To remove the clamp:**

Loosen the setscrews (T1) until they extrude and remove the clamp from the dovetail (Fig.19).

- **To install the clamp:**

Place the clamp in the dovetail by pushing as far as it will go and then fix in place by fastening the setscrews (T1).

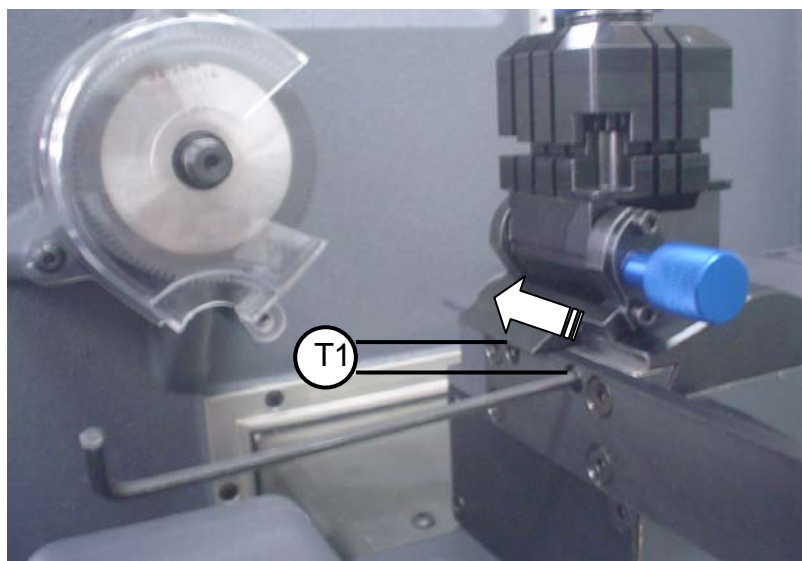

Fig.19

## 3.2 AVANTCODE (KEY FEEDER)

### 3.2.1 USING THE AUTOMATIC CLAMP

Place the keys in the automatic clamp using the key feeder. The key leaves the feeder as the carriages move, the back of the key is positioned on the lower jaw of the automatic clamp and once in position, the upper jaw comes down to clamp the key. The upper jaw is raised and lowered by an electric motor.

Keys that can be cut in the automatic clamp:

- Key thickness: 1.8 - 2.8 mm
- Max. cutting depth: 3.9 mm.
- Keys cut down one side.

Keys that cannot be cut:

1. Keys with a plastic bow, cross keys and pointed tip.

The required parameters enabling you to use the key feeder to cut a key are specified in the image below (Fig.20).

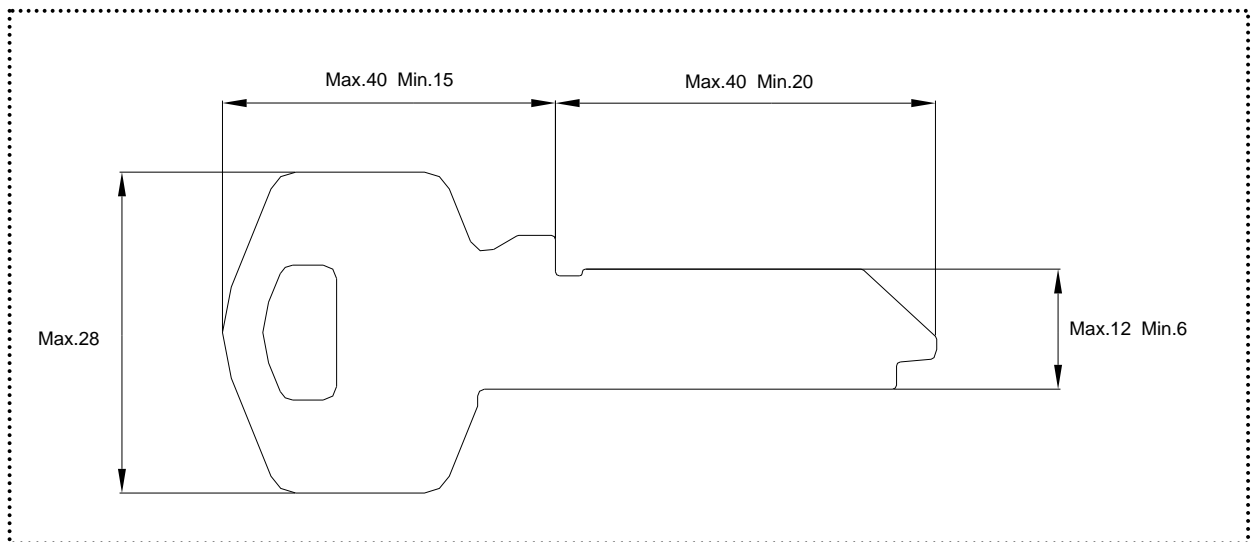

Fig.20

### 3.2.2 USING THE FEEDER

The loading system places the key in the automatic clamp when the machine carriages advance towards the feeder. The parameters of the key in the feeder are the same as that in the automatic clamp. You can place approximately 50 keys in the feeder.

Points to remember when placing and adjusting keys in the feeder:

1. Placing the key in the feeder.

The keys must be placed with the bow towards the left and the back towards the operator (Fig.22)

2. Adjusting the key blade.

Adjust the screw (T2) to support the part (P1) on the key blade and then move away by about 1 mm (Fig 21-22).

3. Adjusting the key bow.

Loosen the screw (T3) and turn the part (P2) to support the plate (P3) on the key bow and then move away by about 1 mm (Fig.21-22).

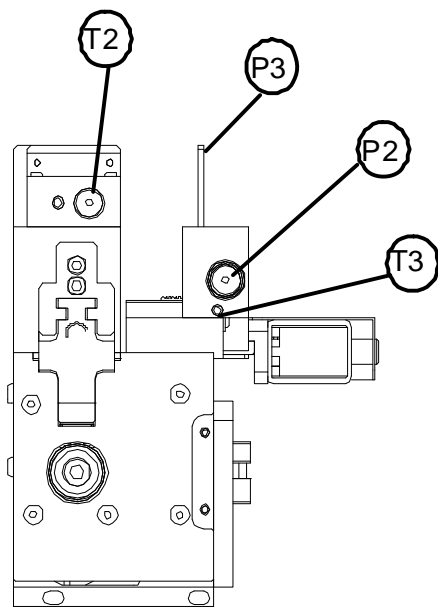

Fig.21

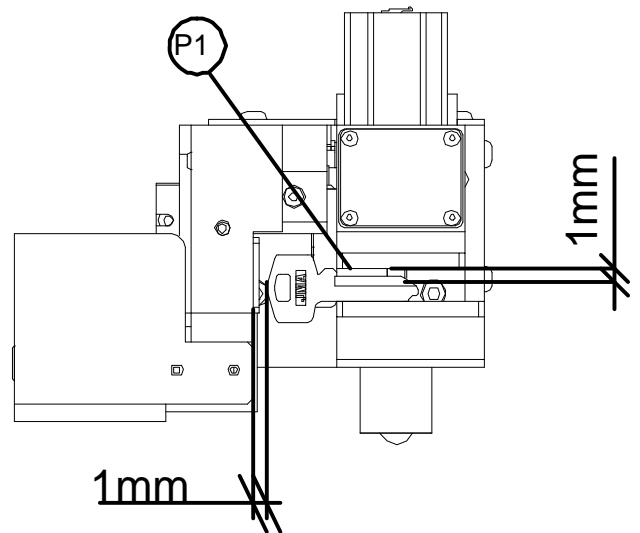

Fig.22

4. *Adjusting the height of the loading system: The height of the key exit can be adjusted by raising or lowering the feeder. Follow these steps to do so:*
  1. *Loosen the screws (T4), turn the screw (T5) raise or lower the feeder.*
  2. *Once you have adjusted the height, fasten the feeder in place by tightening the screws (T4).*

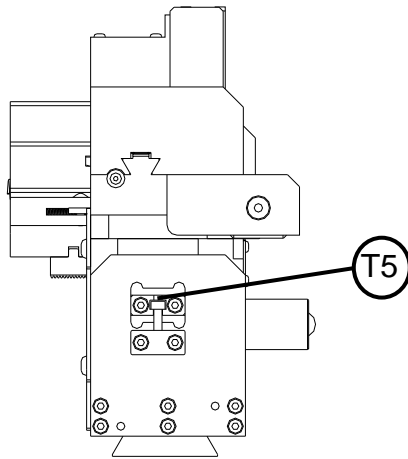

Fig.23

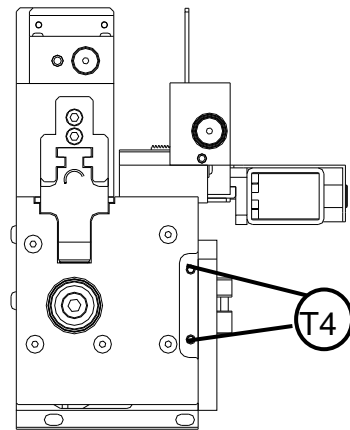

Fig.24

### 3.2.3 ASSEMBLY AND DISASSEMBLY OF THE AUTOMATIC CLAMP & FEEDER

The following section explains how to mount the key feeder.

- 1) **Remove the cover:** Loosen the setscrews (T6) until they extrude and remove the cover (P4) from the dovetail (Fig.25).
- 2) **Remove the standard clamp:** Loosen the setscrews (T7) until they extrude and remove the standard clamp unit (Fig.26).
- 3) **Insert the automatic clamp:** Insert the automatic clamp in the dovetail as far as it will go and then tighten the setscrews (T8) to fix the clamp in place (Fig.27).
- 4) **Insert the automatic feeder:** Insert the automatic feeder as far as it will go and tighten the setscrews (T9) to fix the feeder in place (Fig.28)..

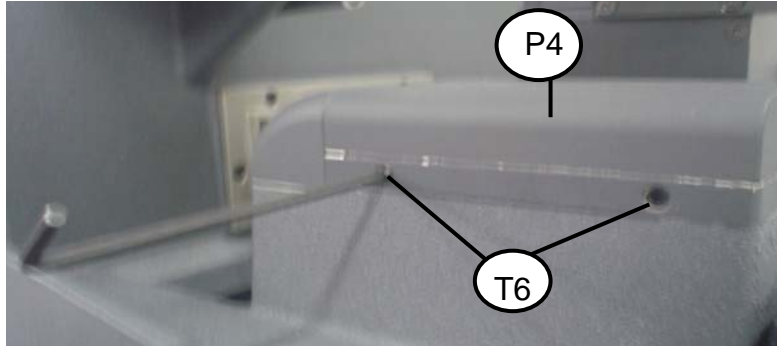

Fig.25

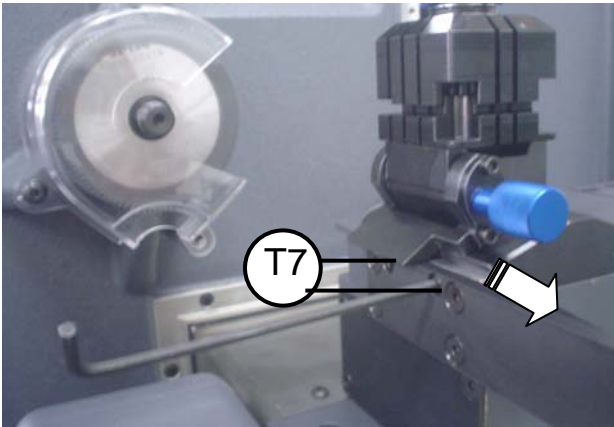

Fig.26

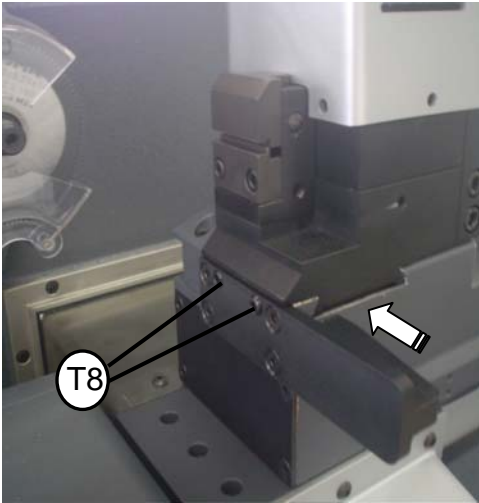

Fig.27

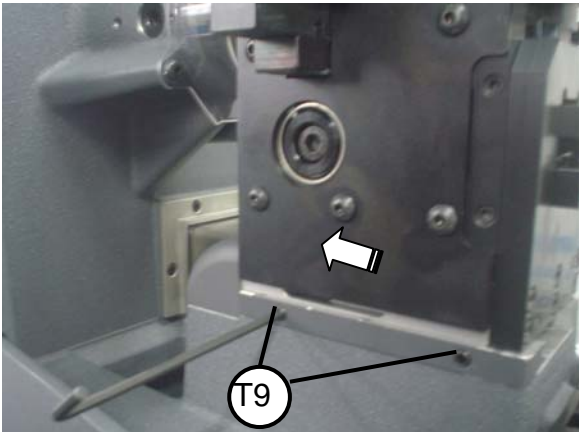

Fig.28

### 3.3 CONVERT THE AVANTCODE (STANDARD) INTO AN AVANTCODE (KEY FEEDER)

Converting the AVANTCODE (STANDARD) into an AVANTCODE (KEY FEEDER) only involves mounting the key box for automatic unloading. Step-by-step instructions for how to perform this conversion are set out below:

Mounting the key box:

- Release the screws (T10) of the decorative case (Fig.29).
- Position the key box holder and fasten in place using the screws supplied (T11) (Fig.30).
- Insert the key box (P5) in the holder (Fig.31)

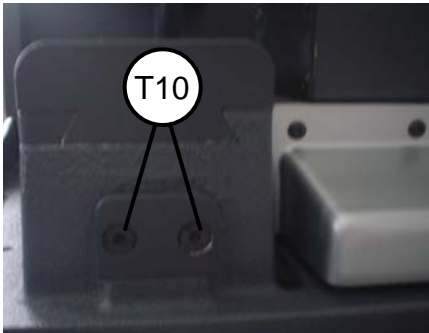

Fig.29

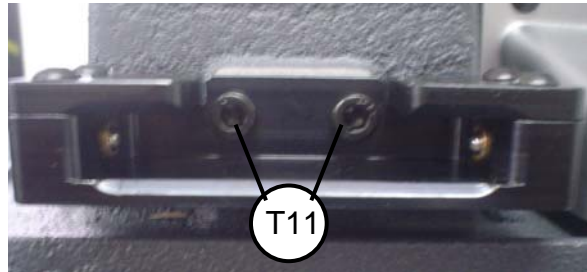

Fig.30



Fig.31

## 4 OPERATION MANUAL

The machine's main menu is represented on the following screen:



Each icon represents the following:

-  *Cut key*
-  *Read key*
-  *Copy key*
-  *Edit files*
-  *Configuration*
-  *Maintenance*

## 4.1 CUT KEY



This function is used to make a direct copy of the key. There are 4 different ways of cutting the key within this option, according to its:

- **File:** Enter the file name or number (for a known file) for the key, or modify a file if one has already been created or edited.
- **Manufacturer-model:** Enter the key's manufacturer and model.
- **Manufacturer -serial number:** Enter the manufacturer and serial number.
- **Key type:** Enter the key type.

Follow these steps to cut the key:

- Press the "CUT KEY" icon. Once it has been pressed, the next screen appears with the 4 options.

CUT KEY
Select by:
File
Manufacturer- model
Manufacturer - series
Key type

The steps to take for the various options are explained below:

### 1. FILE

- Enter the file name or number and press ENTER.

CUT KEY
File name:
-----
Edited file

- Then enter the bits and press ENTER.

CUT KEY	
File:476	Side: A
Serial no.:1234567890	
Bit code:	
-----	

- The following screen is for information only, it tells us which mill bit and clamp to use and how to secure the key in the clamp (See section 3.1.1).

CUTTING INFO		
	Milling tool	FP16W
	Clamp	MP1
	Clamp side	1
	Clamp stop	C

- Open the clear shield and place the blank key in the clamp, in accordance with the cutting information.
- Close the shield and press ENTER.
- The following options appear on the final screen, select one and press ENTER.

CUT KEY	
Cut key	
New bitting	
Number of keys	
Cut - electricity	
Cut type	NORMAL
Material:	
Steel – nickel silver	

Each option represents the following:

Cut key: Start the cutting process.

New bittings: Changes the number of key bittings.

Number of keys: The number of keys to cut is defined. The machine will cut one key by default. If more keys are selected, a counter shows the number of keys that have been cut and the total to cut.

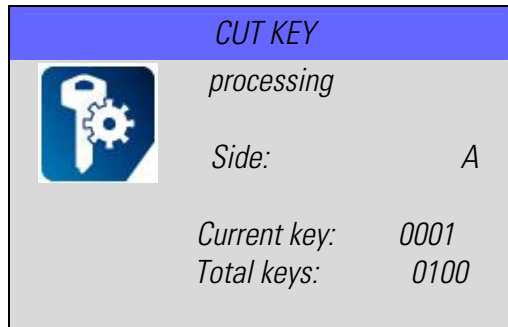

When configuring using the clamp an information screen appears once the first cutting cycle has been completed.

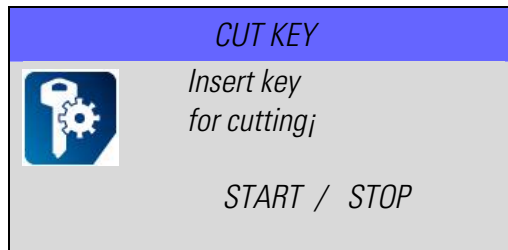

When configuring using an automatic clamp, the counter will automatically add the keys and the machine will stop once it reaches the total number of keys or when the loading system is empty. If the loading system is empty, re-fill it and press ENTER.

Cut - electricity: Can be used to cut the key with electricity. (See section 2.8)

Types of cut: Used to perform various types of cut. (See section 2.9)

Material: The carriage speeds are different depending on the type of material to cut. There are three speeds for the various key families: steel-nickel silver, brass and aluminum.

## 2. Manufacturer-model

- Select the key manufacturer and press *ENTER* on the keyboard.  
(NB: The list of manufacturers is in alphabetical order)

MANUFACTURER
ABBES
ABSA
ABT
ABUS
AGA



— Arrow to move the cursor up



— Arrow to move the cursor down

- Press the *CLEAR* button on the keyboard or write the manufacturer initials to perform a quick search for the key. Once you have selected the key, press *ENTER* on the keyboard.

SEARCHING...
TESA

- The next step is to select the key type and press *ENTER* on the keyboard.

Model
ABU-4I
IF-120
IS-1D
TE-8I
VI-2I



— Arrow to move the cursor up

XXX/XXX

N. of reference in the main screen

Total number of references



— Arrow to move the cursor down

- Once you have selected the model, its characteristics are displayed: profile, serial number, file and system.

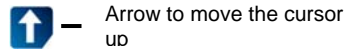

TE-8I			
Perfil	Serie	Ficha	Sistema
.....A	1234567890	476	
.....B	1234567890	476	

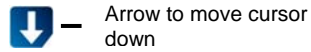

Ref. Number on main screen

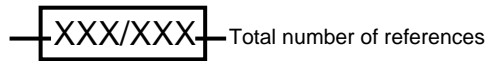

- Select the specific key you wish to cut and press ENTER on the keyboard.

(NB: If the machine has a key feeder set up and you choose a double sided key or car key with a plastic bow and information screen will appear).

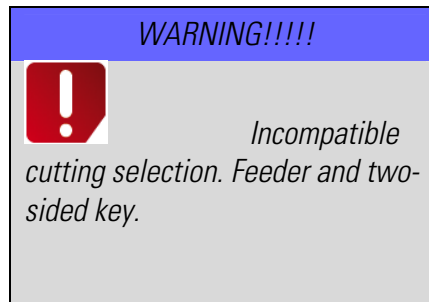

- Once you have selected the key you wish to cut, the steps or screens to follow to cut the key are the same as those that appear under the CUT=>FILE option. (Section 4.1)

<i>CUT KEY</i>	
<i>File</i>	<i>:476</i>
<i>Side:</i>	<i>A</i>
<i>Serial no.:</i>	<i>1234567890</i>
<i>Bitting code:</i>	<i>-----</i>



<i>CUTTING INFO</i>	
<i>Milling tool FP16W</i>	
<i>Clamp</i>	<i>MP1</i>
<i>Clamp side</i>	<i>1</i>
<i>Clamp stop</i>	<i>C</i>



<i>CUT KEY</i>	
<i>Cut key</i>	
<i>New bitting</i>	
<i>Number of keys</i>	
<i>Cut - electricity</i>	
<i>Cut type NORMAL</i>	
<i>Material:</i>	
<i>Steel – silver nickel</i>	

### 3. Manufacturer – serial number

- Select the key manufacturer and press **ENTER** on the keyboard.  
(Note: The manufacturer list is in alphabetical order)

Manufacturer - Serial
ABBES
ABSA
ABT
ABUS
AGA



— Arrow to move the cursor up



— Arrow to move the cursor down

- Press the **CLEAR** button on the keyboard or write the manufacturer initials to perform a quick search for the key. Once you have selected the key, press **ENTER** on the keyboard.

SEARCHING ....
TESA

- Then select the key and press **ENTER** on the keyboard..



— Arrow to move the cursor up

TESA			
Modelo	Perfil	Serie	Ficha
ABU-4I		12345	235
IF-120		12345	566
IF-120		0001-0004	592
IS-1D		123456	334



— Arrow to move the cursor down

Reference number on main screen

XXX/XXX

— Total number of references

(NB: If the machine has a key feeder set up and you choose a double sided key or car key with a plastic bow an information screen will appear explaining that this key is incompatible with the application).

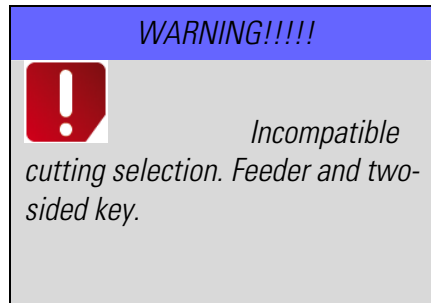

- Once you have selected the key you wish to cut, the steps or screens to follow to cut the key are the same as those that appear under the CUT=>FILE option. (Section 4.1)

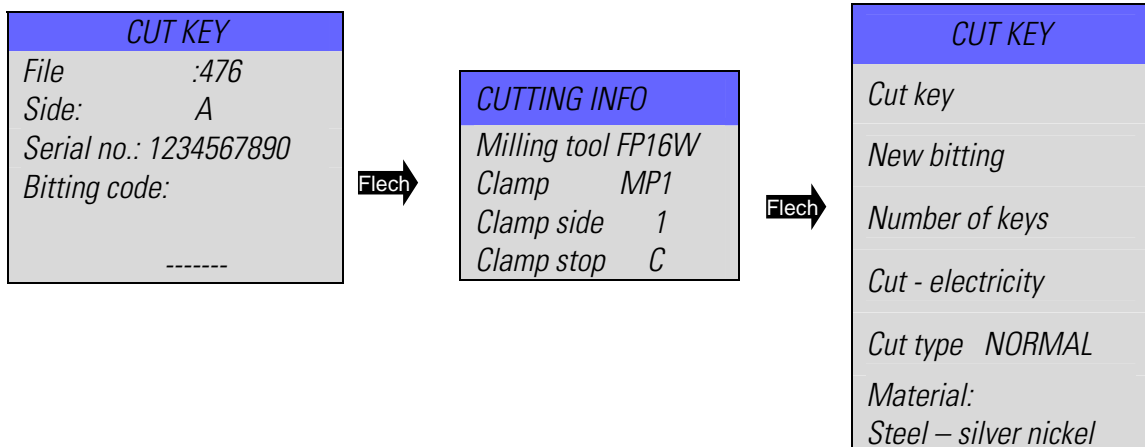

#### 4. Key type

- Select the key and press ENTER on the keyboard.  
(NB: The list of manufacturers is in alphabetical order)

KEY MODEL
AB-10I
AB-1D
AB-1I
AB-4D
AB-5D

 — Arrow to move the cursor up

 — Arrow to move the cursor down

- Press the **CLEAR** button on the keyboard or write the manufacturer initials to perform a quick search for the key. Once you have selected the key, press **ENTER** on the keyboard.



- Then select the specific key to cut.

<i>TE-8I</i>			
<i>Profile</i>	<i>Serial</i>	<i>File</i>	<i>System</i>
<i>.....A</i>	<i>1234567890</i>	<i>476</i>	
<i>.....B</i>	<i>1234567890</i>	<i>476</i>	

*(NB: If the machine has a key feeder set up and you choose a double sided key or car key with a plastic bow an information screen will appear explaining that this key is incompatible with the application).*

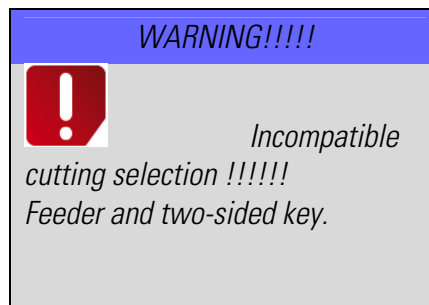

- Once the key to cut has been selected, the following screens are the same as those that appear under the CUT => FILE option. (Section 4.1).

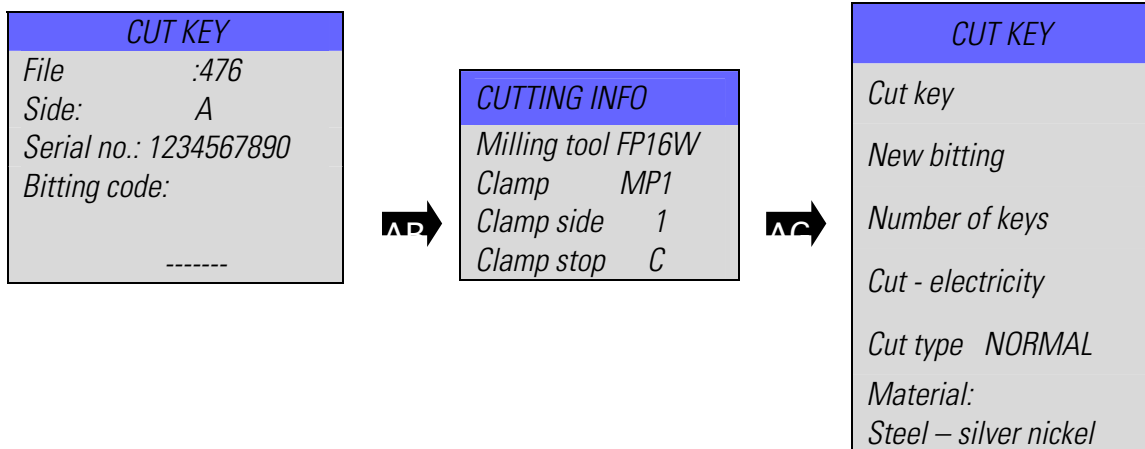

## 4.2 READ FILE



This function is used to read the key, bearing in mind the file, manufacturer or key type. The steps to follow to manually read the key are as follows:

- Press the "Read key" icon. Once you have pressed this icon, the next screen appears showing 4 options to select the key type. (See section 4.1).

READ KEY
Select by:
File
Manufacturer- model
Manufacturer - serial
Key type

- Once you have selected the key, press ENTER on the keyboard.

- *Open the clear shield and place the key in the reading clamp, bearing in mind the corresponding position according to the information in the file. Close the shield and press ENTER on the keyboard.*

*(NB: There must be no keys present in the feeder at this point. If there are, the machine will prevent you from reading the key.)*



- *Once the key has been read, the following window appears.*

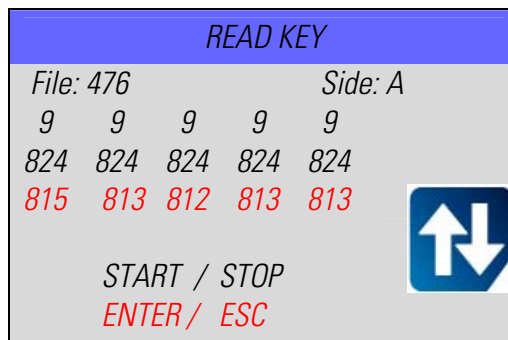

1. *When you press the START button the machine will cut the values of the original key file.*
  2. *When you press ENTER, the machine will cut the values read by the laser.*
- *The same options as those under the "Cut key" screen appear on the last screen.*

*(See section 4.1)*

<i>CUT KEY</i>
<i>Cut key</i>
<i>New bitting</i>
<i>Number of keys</i>
<i>Cut - electricity</i>
<i>Cut type NORMAL</i>
<i>Material:</i> <i>Steel – silver nickel</i>

- *Select the option and press the ENTER button on the keyboard.*

### 4-3 COPIAR LLAVE



This function is used to copy a key. The key can be cut using two distinct methods

- Saved copy: Duplicates a key from a previously saved copy. Follow the steps described below:

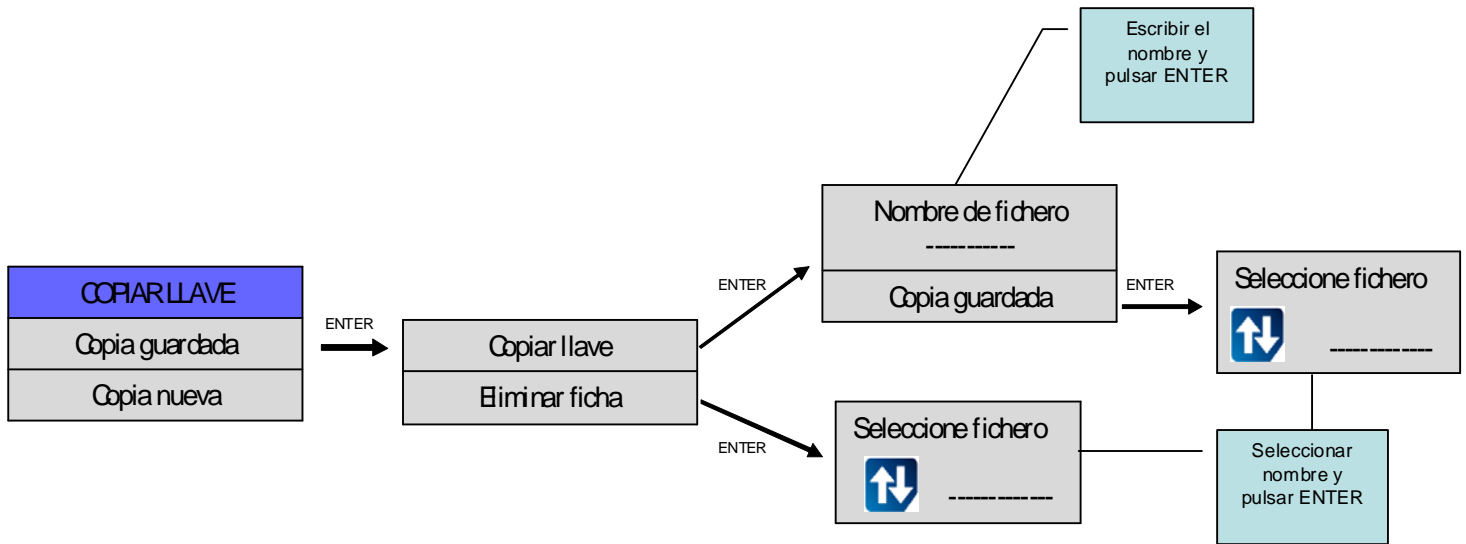

1. New copy: Cuts a new key.

- Select "New copy" and press ENTER.

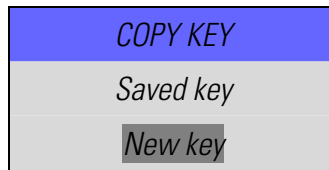

- The following screen appears:

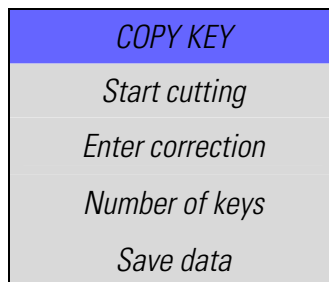

A. "Start copying". Cuts the key that has been placed in the reading clamp.

- Select "start copy" and press ENTER.

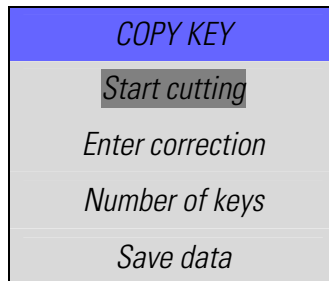

- When you press ENTER the following window appears.



- Open the clear shield, place the key in the reading clamp and close the shield.
  - Press the START button, to start the cutting process.
- B. "Enter. Correction". Allows you to correct any imperfections in the new key's depth and/or encryption. This is normally used for severely worn keys.
- Select "Enter correction" and press ENTER.

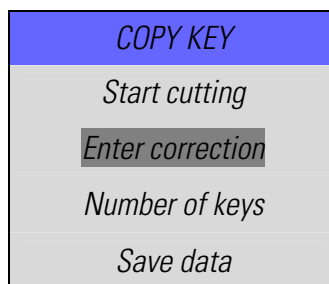



- Enter the correction values to create the desired key:

Correction values: The operator can modify the "depth" and "spacing" parameters.



Changing the depth values (positive or negative) means raising or lowering all of the encryption (Fig.32)

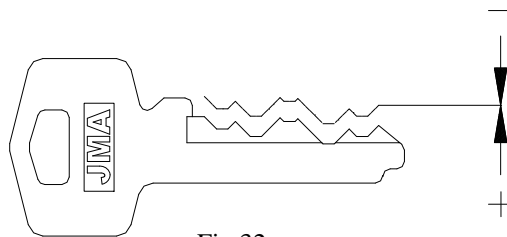

Fig.32



The entire encryption is moved to the left or to the right (towards or away from the tip (Fig.33)

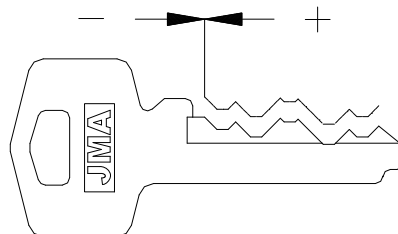

Fig.33

- Open the clear shield, place the key in the reading clamp and close the shield.
- Press ENTER and you will see the previous window.

<i>COPY KEY</i>
<i>Start cutting</i>
<i>Enter correction</i>
<i>Number of keys</i>
<i>Save data</i>

- *Select "start copy" and press ENTER.*

*c. Number of keys*

<i>COPY KEY</i>
<i>Start cutting</i>
<i>Enter correction</i>
<i>Number of keys</i>
<i>Save data</i>

- *Press the ENTER button. Open the clear shield, place the key in the reading clamp and close the shield.*

<i>COPY KEY</i>
<i>Number of keys</i>
-----

- *Enter the number of keys you want to cut and press ENTER.*

*D. Save information*

- *Select the Save information option and press ENTER. Open the clear shield, place the key in the reading clamp and close the shield.*
- *Once the new key has been cut, enter the name of the key and press the ENTER button.*

<i>Save data</i>
<i>File name:</i>
-----

## 4.4 EDIT FILE



The machine comes equipped with a key editor which allows you to create and save your own keys, either because you are a lock manufacturer with special keys, because you master keys, or because a new key has been released onto the market which was not included in the machine.

All of the keys created using the key editor can then be modified and even deleted.

(NB: The files that come pre-installed in the machine by default, for door, car and commercial locks cannot be altered using the key editor, meaning that the user cannot modify or delete them.)

The steps to create, modify or delete a file are described below:

### 4.4.1 CREATE FILE

1. Select "EDIT FILE" from the main menu.

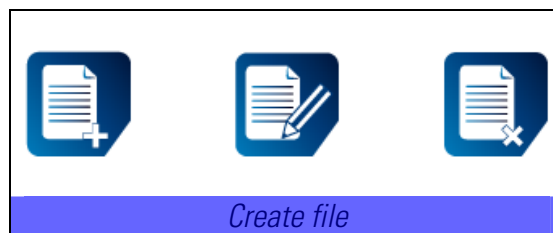

2. Press the "CREATE FILE" icon.



3. Enter a key file name and select the type of key (flat or vertical-stop lock). The name can comprise letters or numbers (remember that to select various alpha-numeric characters you have to press the key more than once, depending on the position of the character).

(See section 2.7.)

EDIT FILES	
File name:	-----
Key type: <	flat

4. When you create or modify a file, you have to complete various tables.
5. The first one is as follows:  
(NB: Complete the fields and then press ENTER)

- **Probe: ENABLE/DISABLE:** Enables/disables reading the key using a laser sensor.
- **Adapter:** Adapter reference (if required).
- **Milling machine:** Milling machine used to cut the key. The machine comes fitted with the FP16W milling tool, which can be used for all flat keys. If you are using a special key type and need another milling tool, add the corresponding reference here.

(NB: The Avantcode cannot use any milling tools that have not been specially designed for it and supplied by JMA)

- **Clamp:** Standard clamp reference. The machine comes equipped with the MP1 clamp. See section 4.1.1
- **Key tip:** See section 4.1.1
- **Clamp tip:** See section 4.1.1
- **Clamp side:** See section 4.1.1

EDIT FILES	
Probe	ENABLE
Adapter	-----
Milling tool	FP16
Clamp	MP1
Key stop	C
Clamp stop	1
Clamp side	1

6. The second table,

- **Key width:** The keyblank width.
- **Y current:** Y position, where the reference for the electricity contact is taken.
- **Type of cut:** (See section 3.4.)
- **Angle:** Key biting angle.
- **Supports:** Number of pins or teeth on the key.
- **Speed:** The cutting speed of the machine carriages.
- **Number of sides:** The number of sides to be cut, if the key is defined as having two sides, the machine asks which file is to be used to cut side B. If it's a symmetrical key (LMec.2) use the same file name as the file being created. If it's asymmetrical (LMec.3), the name of the file to be used to cut side B must be entered.

EDIT FILES	
Key width	-----
Y current	-----
Type of cut	NORMAL
Angle	---
Supports	--
Speed	-
Number of sides	-

7. The third table **Symbols/Depth:** is for the cut depth. Each symbol is given a depth.

EDIT FILES	
Symbol./Depth:	
--/-----	--/-----
--/-----	--/-----

8. The fourth table, **Spaces:** is the distance between the key's teeth or pins.

This data is defined in the following manner:

- First space = from the collar of the key to the first pin or support.
- The following spaces refer to the relative spaces between the pins. I.e. the spaces between the supports or indents.
- If the tip is pointed, an extra space needs to be added - the distance between the top and the last support on the key.

EDIT FILES			
Spaces:			
---	---	---	---
---	---	---	---

9. And finally, **Bases**: is the width of the blade supporting the biting on the key.

EDIT FILES			
Bases:			
---	---	---	---
---	---	---	---

Example of how to complete tables 3, 4 and 5 (Fig.34):

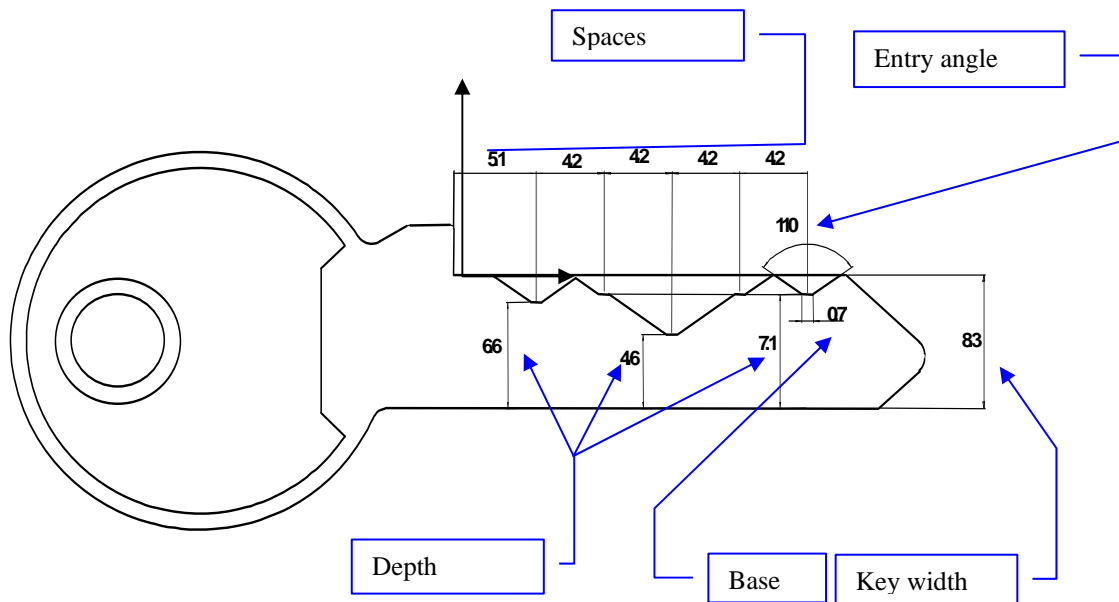

Fig.34

*Flat key with 5 supports with different depths:*

- 7.1 mm = 710 (hundredths of a millimeter)
- 6.6 mm = 660 (hundredths of a millimeter)
- 6.1 mm = 610 (hundredths of a millimeter)
- 4.6 mm = 460 (hundredths of a millimeter)

*(NB: All values must be entered as hundredths of a millimeter)*

*Enter the data as follows:*

EDITING FILES	
Symbol/Depth:	
01/710	03/610
02/660	04/460

When entering the data, leave the symbol field blank and press ENTER. The program will understand that the depth registration process has finished and will continue to the next table.

Complete the next table with the distances between the pin axes. The number of data to enter is determined by the number of supports defined in the previous file.

EDITING FILES				
Spaces:				
510	420	420	420	420
---	----	----	----	

The final piece of information to specify in this form is the width of the base on which the pin is supported. The file allows each support to be variable. The number of data to enter is the same as the number of pins. All the data must be entered as hundredths of a millimeter.

EDITING FILES				
Bases:				
07	07	07	07	07
---	----	----	----	

(NB: You can always correct the data by using the cursors or arrows and overwriting the character)

#### 4.4.2 MODIFY FILE

Once you have created the files, you can then modify and readjust the values until you achieve the desired key.

- Starting from the main menu, the sequence to reach this point is as follows:

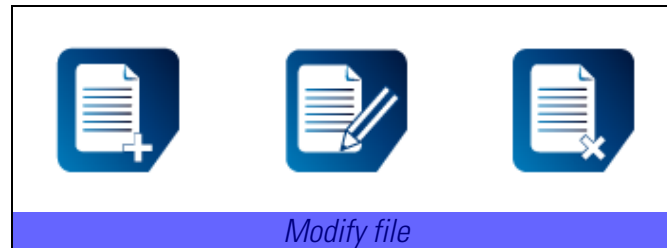

- Press the "Modify file" icon



- In the next screen you can see the files previously created and use the up and down arrows to visualize the various files, until you find the file you wish to modify.



(NB: You can leave and return to the main menu at any time by pressing ESCAPE.)

- Once you have located the file, press ENTER to select. The file is now selected and you continue to the data defined in the previous chapter on editing files. Progress through the data by pressing ENTER and go back using the ESCAPE button.
- Change an entry by simply overwriting it with another value.
- Once modified, the file values are overwritten and the file has been modified.

#### 4.4.3 DELETE FILE

Once you have created the files, you can delete them from the memory.



- Press the "DELETE FILE" icon.
- In the next screen you can see the files previously created and use the up and down arrows to visualize the various files, until you find the file you wish to delete.

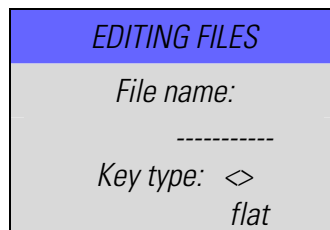

- Once you have located the file, select it and press the ENTER button to delete it from the memory.

#### 4.5 CONFIGURATION



The machine leaves the JMA factory having been calibrated and is ready for use.

As described earlier, the AVANTCODE machine can have two distinct configurations (See section 3):

1. AVANTCODE (STANDARD): Clamp and reading clamp.
2. AVANTCODE (KEY FEEDER): Automatic clamp and feeder and reading clamp.

Each time the AVANTCODE configuration is changed from STANDARD to KEY FEEDER or vice-versa, you need to calibrate the machine prior to performing any operation (cutting, reading or copying a key). If it has not been calibrated, an information screen will appear.

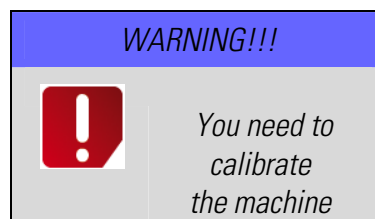

The calibration process is carried out using a calibration template (CRG), which you will find in the accessories box. (Figure.35)



Fig.35

The calibration process for each part is explained in detail below.

Once you have selected the "CONFIGURATION" icon, the display reads:



Configure AVANTCODE (STANDARD): Adjust the milling tool "Calibrate milling tool" and then it's a good idea to adjust the reader "Calibrate reader". It's a good idea to adjust the reader for the "Cut key" option (See section 4.3.). If it is not calibrated, the first key will be cut with a calibration error, however the following keys will be cut correctly.

Configure the AVANTCODE (KEY FEEDER): Adjust the feeder: "Calibrate feeder", but you do not have to calibrate the reader "Calibrate reader".

(NB: The calibration template (CRG) and the area where the milling tool touches the template must be clean to avoid calibration errors. Clean both parts with the brush before calibration.) (Fig.36 and Fig.37.)

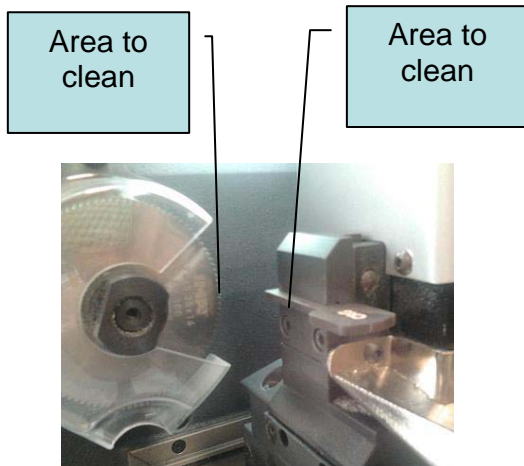

**Avantcode (Key Feeder)**

Fig.36

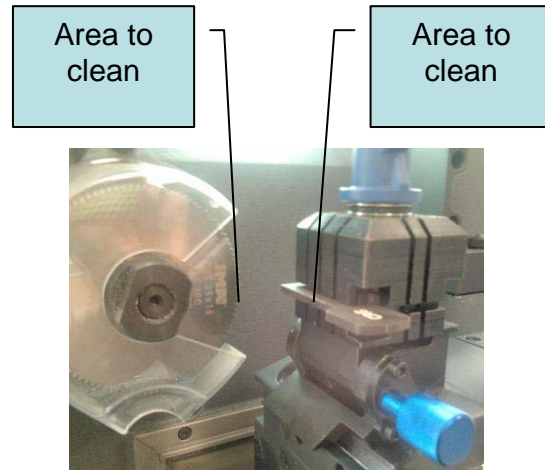

**Avantcode (Standard)**

Fig.37

The steps to follow to calibrate the clamp, reading clamp and feeder are as follows:

CALIBRATE MILLING TOOL

1. Select the **Calibrate milling tool** icon.
2. The following message appears, informing you of the type of milling tool and clamp to use.

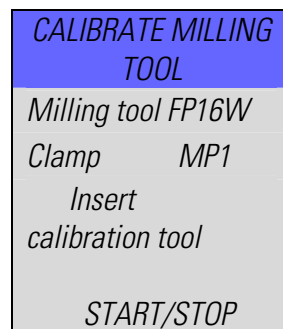

3. Open the clear shield and fasten the calibration template (**CRG**) in the clamp until it reaches the tip of the clamp. (Fig.38)

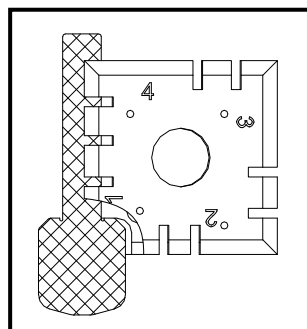
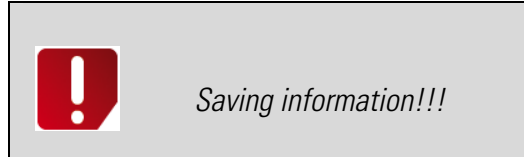

Fig.38

4. Close the shield and press **START**.
5. A "processing" message appears.
6. Once the cycle completes, the following message appears for a moment, and then the screen returns to the calibration menu.



Once the milling tool has been calibrated, you have to calibrate the reading clamp.

CALIBRATE READER

1. Select the **Calibrate reader** icon.
2. The display reads:

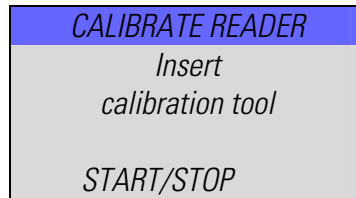

3. Open the clear shield and fasten the calibration template (**CRG**) in the reading clamp until it reaches the tip of the clamp. (Fig.38)
4. Close the shield and press **START**.
5. A "processing" message appears.
6. Once the cycle has completed, the following message will be displayed:

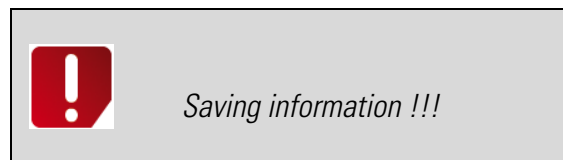

7. If it has not processed successfully, a calibration error message will be displayed

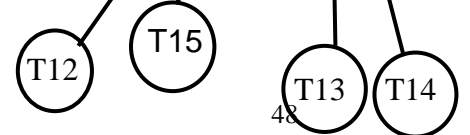
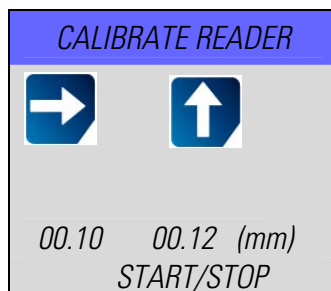

Fig.39

8. Continue as follows (Fig.39):

- If X is not 0, loosen the screw (T12) and use the 2 Allen key to advance or go back according to the directions indicated on the display, by turning the screw (T13).

(NB: Turning the screw (T13) a quarter turn produces a 13 hundredths of a millimeter movement).

- If Y is not 0, loosen the screw (T14) and use the 2 Allen key to advance or go back according to the directions indicated on the display, turning the screw (T15).

(NB: Turning the screw (T15) a quarter turn produces a 13 hundredths of a millimeter movement).

9. Fasten the (T12 / T14) screw and press START.

10. Once the milling tool has been calibrated, the following message appears for a moment, and then the screen returns to the calibration menu.

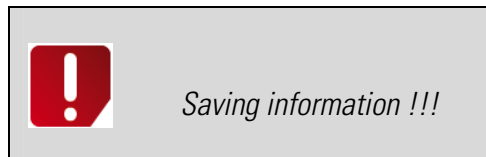

(NB: Differences of +- axes are acceptable).

0.02 mm on the X and Y

(NB: By pressing ENTER, the machine saves the adjusted values that the operator has just calibrated)

And finally, analyze the feeder calibration.

### CALIBRATE FEEDER

1. Select the **Calibrate feeder** icon.
2. The display reads:

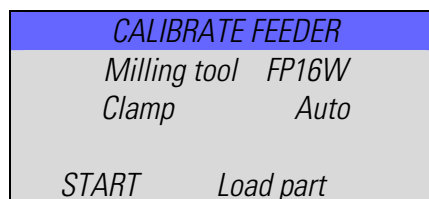

3. Open the clear shield and position the calibration template (**CRG**) in the feeder. (See section 3.2.2, Fig.21, Fig.22).
4. Close the shield and press START.
5. A "processing" message appears.
6. Once the cycle completes, the following message appears for a moment, and then the screen returns to the calibration menu.



*Saving information!!!*

## 4.6 MAINTENANCE



*This function is used to check the various machine values, such as:*

- *Manufacturer values*
- *Data connection*
- *Information*
- *Speed*
- *Password*
- *Other options*

### 4.6.1 Manufacturer values



*This function allows you to restore the manufacturer's settings. A warning message is displayed on the screen, telling you that you will lose all the information stored in the memory.*

### 4.6.2 Data connection



*This function allows you to transfer information. You can transmit information in two distinct ways: loading data using a USB memory or configuring a network.*

### 4.6.3 Information



*This function allows you to visualize the machine references, software, PC connection and number of keys cut.*

### 4.6.4 Speed



*This function allows you to change the speeds of the machine carriages, both the carriage that positions the key by the mill and the cutting carriage.*

### 4.6.5 Password



*This function allows you to change the machine parameters. It can only be used with Alejandro Altuna authorization and technical support.*

#### 4.6.6 Other options



*Other machine functions:*

- *Language*



*The various languages in which the machine can be used are displayed These languages are:*

- *Spanish*
- *English*
- *French*
- *German*
- *Italian*
- *Portuguese*

*Once you have selected the language, press ENTER or ESCAPE to leave the menu.*

- *Adapter*



*The various key adapter models supplied with the machine appear in this section.*

- *Check*



*The machine's 4 parts: the sensors, memory, motors and milling tool are checked in this section.*



1. *Sensors: The shield sensors, automatic clamp sensor, the electromagnetic coil of the feeder that hits the keyblank and the key feeder sensor.*



2. *Memory. Analyses the memory status.*



3. *Motors. Move the up-down and left-right arrows to move the motors that move the carriages and press escape to return to their original position.*



4. *Milling tool. Press button 1 to activate the milling tool and button 2 to stop it.*

- *Touch screen*



*Allows you to activate, deactivate or calibrate the touch screen. Select the option and press ENTER, otherwise ESCAPE to EXIT.*

- *Save energy*



*You can select 3 energy levels, low, medium and high, with this function. Select the option and press ENTER, otherwise ESCAPE to EXIT.*

- *Continuous movement*



*This section allows you to move the X and Y carriages continuously. Press ENTER to start and STOP to stop. Press ESCAPE to return the carriages to their start-up position.*

## 4.7 PC OPERATION



*In this application, the machine enters slave mode, i.e. it is commanded by a PC. The machine must be connected using a serial port. (See section 2.5, Fig.5).*

*If you press the "PC COMMUNICATION" function again, the machine will return to its normal operating mode.*

*(NB: When the machine is turned off while connected to a PC, it will still be connected to the PC when it is turned back on)*

## 5 **CLEANING AND SAFETY**

*We recommend you follow these steps when cleaning:*

- *Keep the operational parts of the machine as clean as possible, remove shavings using the brush*
- *Do not use compressed air to clean the working area with shavings, as this will push them into the operating parts.*

*For your own safety, we recommend you follow these steps:*

- *Do not try to start or handle the machine until all of the safety issues, assembly instructions, user guide and maintenance procedures have been completed and understood.*
- *Always disconnect the electricity supply before carrying out any cleaning or maintenance tasks.*
- *Make sure your hands are dry when working.*
- *Ensure that the machine is earthed.*

## 6 **MAINTENANCE**

*Before undertaking any maintenance operations, you must comply with the following:*

- *Never carry out any maintenance when the machine is switched on.*
- *The power cable must always be disconnected.*
- *Follow the manual instructions to the letter.*
- *Use original spare parts.*

*(NB: Use lubricants for preventative machine maintenance. Make sure that maintenance products do not come into contact with the electronic parts).*

## 6.1 LOCATING MALFUNCTIONS

<b>MALFUNCTION</b>	<b>PROBABLE CAUSE</b>	
<i>The machine is turned on, but the display is blank</i>	<i>Emergency button pressed down</i>	
	<i>The display-keyboard is broken</i>	
	<i>The cable from the display screen to the control board is badly connected</i>	
<i>The optical reader is not working</i>	<i>Dirt on the glass conical part of the laser reader</i>	
	<i>The cable from the reader to the control board is badly connected</i>	
	<i>The optical reader is broken</i>	
	<i>The control board is broken</i>	
<i>The X and Y motors are not working</i>	<i>None of the motors are working</i>	<i>Faulty control board fuse</i>
		<i>Control board is broken</i>
	<i>A motor is not working</i>	<i>Badly connected connector cable</i>
		<i>Control board is broken</i>
<i>The automatic clamp is not working</i>	<i>The automatic clamp has not been correctly inserted in the SUB-D connector.</i>	
	<i>The cable from the feeder to the control board is badly connected</i>	
	<i>Faulty cable in the automatic clamp</i>	
<i>The feeder is not working</i>	<i>The feeder has not been correctly inserted into the SUB-D connector</i>	
	<i>The cable from the feeder to the control board is badly connected</i>	
	<i>Faulty cable in the feeder</i>	
<i>The keyboard doesn't work properly</i>	<i>Keyboard broken</i>	
	<i>The connection from the display screen to the control board is badly connected</i>	
<i>The machine is not communicating with the PC</i>	<i>The cable connecting the PC and the machine is badly connected or damaged.</i>	
	<i>The machine control board is broken.</i>	
	<i>PC port broken.</i>	
<i>The "Close shield" message is displayed on the screen, even though it is already closed</i>	<i>The protective shield is not operating correctly on the micro once closed (Fig.40)</i>	



Fig.40

## 6.2 REPLACING THE FUSES

If the machine fails to start when switched on, check the fuses. The machine has two fuses: one is located in the back and the other in the machine control board. Follow these steps to change the fuse:

1. Turn off the machine off at the main switch and disconnect the power cable.

### Rear fuse:

1. Remove the fuse holder beneath the main switch on the back of the machine (Fig.41)
2. Use a tester to check whether the fuse has blown, and if necessary replace it with an identical fuse. F6A 250V.

(NB: The spare fuses is in the switch general)



Fig.41

### Control board fuse:

1. Release the screws on the machine's lower casing.
2. Remove the fuse from the control board and check whether it has blown, if so, replace it with an identical fuse: T4A 250V (Fig.42)

(NB: The accessory box comes complete with spare fuses)

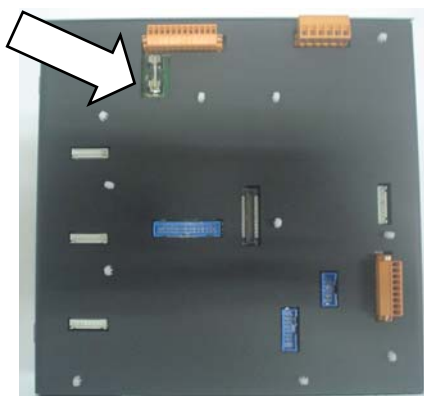

Fig.42

### 6.3 REPLACING AND TENSING THE BELT

Follow these steps to check the tension of the belt or to replace it:

- 1) Turn the machine off at the main switch and disconnect the power cable.
- 2) Unscrew the 6 screws fastening the "motor casing" and remove it. The screws are on the right and left sides, the upper and lower sections.
- 3) Loosen but do not release the 4 screws (T16) supporting the motor. (Fig.43, Fig.44).
- 4) Loosen the nut acting as a locknut (T17).

**Tensing:** Turn the setscrew (T18) (Fig.43) to move the machine motor. When you see that the belt has the right tension, tighten the screw acting as the locknut again (T17) and fasten the 4 screws (T16) supporting the motor.

**Replacement:** Turn the setscrew (T18) anticlockwise to loosen the belt. Remove the broken belt and replace with a new one. Once you have changed the belt, tighten the setscrew (T18) until you can see that the belt has the correct tension. Then fasten the locknut (T17) and the 4 screws (T16) supporting the motor.

- 5) Replace and fasten the "head shield".

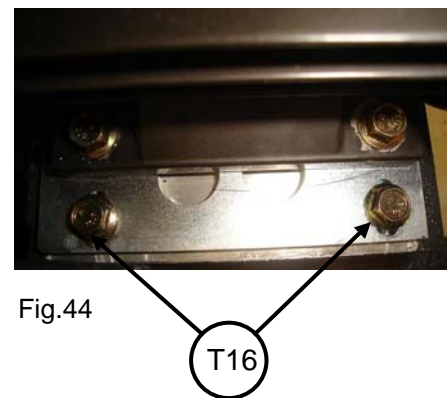
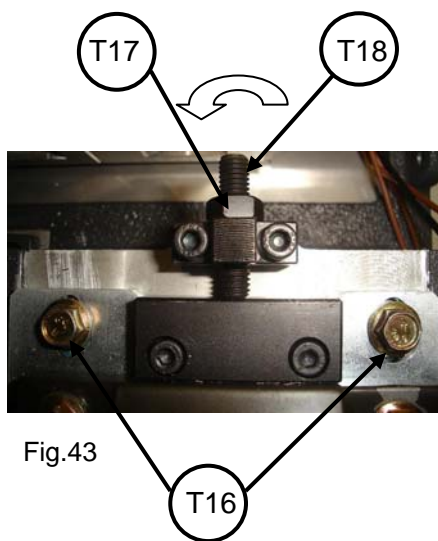

## 6.4 REPLACING THE AUTOMATIC CLAMP SET

Proceed as follows to replace the set of clamps:

- 1) Once you have removed the automatic clamp, unfasten the two screws (T19) and remove the set of clamps (Fig.45).
- 2) Insert the new set of clamps, making sure that they are supported against the inner support.
- 3) Fasten the 2 screws to hold the set of clamps in place.

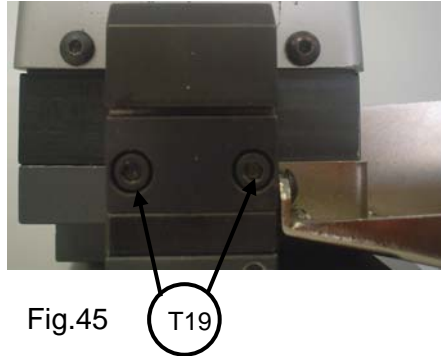

Fig.45

## 6.5 REPLACING THE MILLING TOOL

Proceed as follows to replace the milling tool:

- 1) Turn the machine off at the main switch and disconnect the power cable.
- 2) Lift the front plastic shield.
- 3) Unscrew the 3 screws (T20) holding the milling tool shield. (Fig.47)
- 4) Remove the protective shavings cover (P6). (Fig.46)
- 5) Insert the blocking rod (T21), included in the accessories box. (Fig.48)
- 6) Unscrew the mill bolt (T22) using the 18 mm spanner (T23).  
(NB: Screws left)
- 7) Replace the mill, block the nut, remove the rod from the hole and replace the protective cover.

(NB: If you are installing a new milling tool, you have to calibrate it).  
(See section 4.5.)

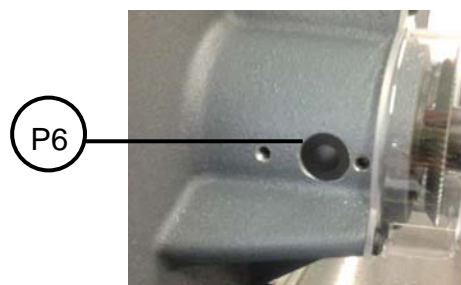

Fig.46

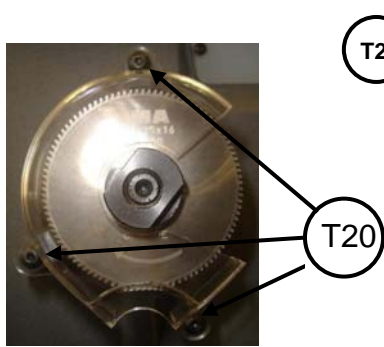

Fig.47

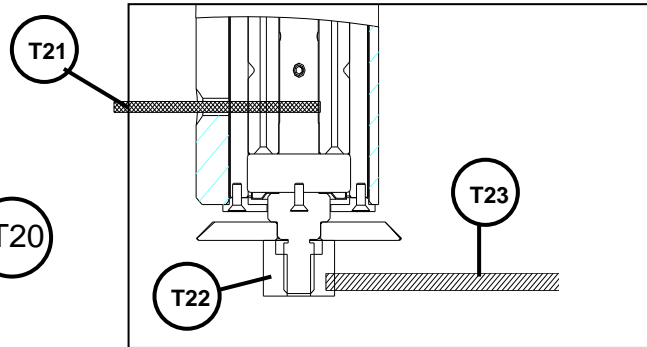

Fig.48

## 6.6 REPLACING THE CARRIAGE SENSOR

### 6.6.1 X AXIS

- 1) Turn the machine off at the main switch and disconnect the power cable.
- 2) Unfasten the two cover screws (T24) and the two screws holding the sensor (T25). (Fig.49, Fig.50).
- 3) Change the sensor and tighten the screws holding the sensor and the cover.

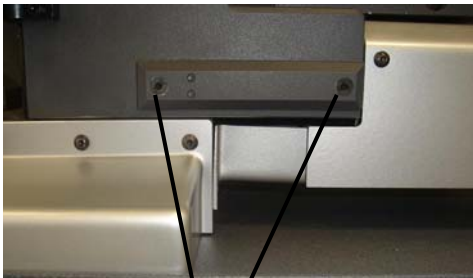

Fig.49

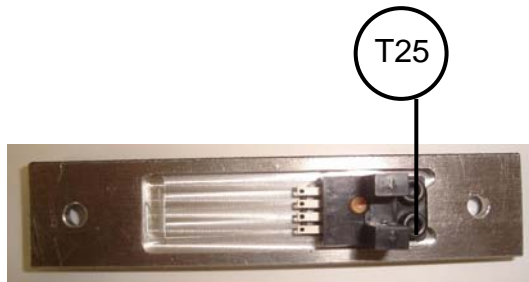

Fig.50

### 6.6.2 Y AXIS

- 1) Turn the machine off at the main switch and disconnect the power cable.
- 2) Release the rear guard covering the back of the machine.
- 3) Release the two screws (T26) that fasten the sensor. (Fig.51)
- 4) Change the sensor and screw it back in place.

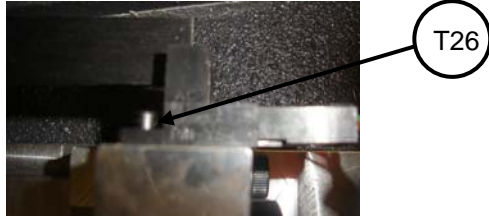

Fig.51

## 6.7 REPLACING THE MOTOR

- 1) Turn the machine off at the main switch and disconnect the power cable.
- 2) Unscrew the 6 screws fastening the "motor casing" and remove it. The screws are on the right and left sides, the upper and lower sections.
- 3) Loosen and remove the belt (see section 6.3).
- 4) Release the cable by disconnecting the connector extruding from the motor casing (Fig.52)
- 5) Release the 4 screws (T27) that fasten the motor to the plate. (Fig.53)
- 6) Replace the motor, fasten the screws, connect the motor cable and tense the belt once you have replaced it.



Fig.52

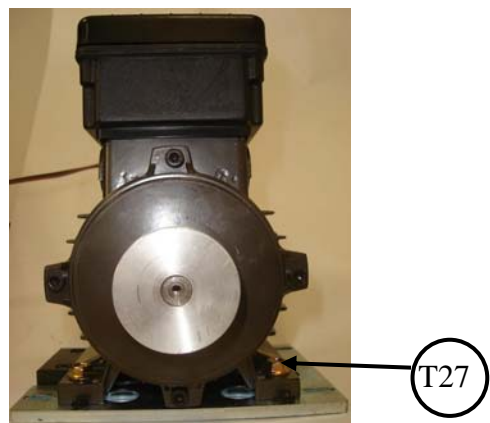

Fig.53

## 6.8 REPLACING THE KEYBOARD

- 1) Turn the machine off at the main switch and disconnect the power cable.
- 2) Release the two screws (T28) holding the keyboard to the bench. (Fig.54)
- 3) Grab the emergency button and lift, turning the keyboard. (Fig.55)
- 4) Release the two connectors (P7) that connect the keyboard to the control board (Fig.55).
- 5) Release the emergency button by turning the lever (P8) towards the right and releasing the bolt that fastens it. (Fig.56)
- 6) Disconnect the two display connectors (P9-P10). (Fig.58)
- 7) Replace the display, connect the two display connectors and emergency button to the new display.
- 8) And finally, screw the new keyboard to the bench using the two screws.



Fig.54



Fig.55

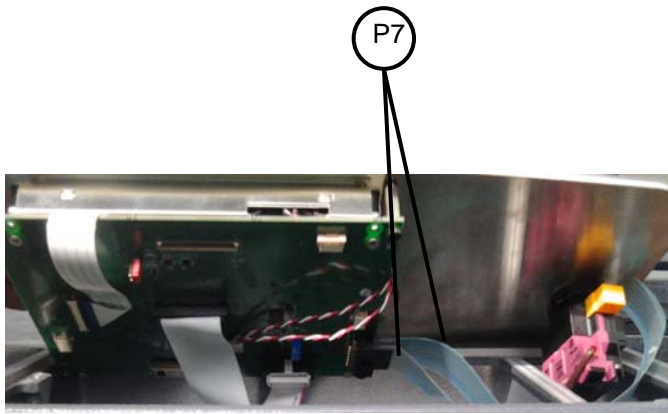

Fig.56

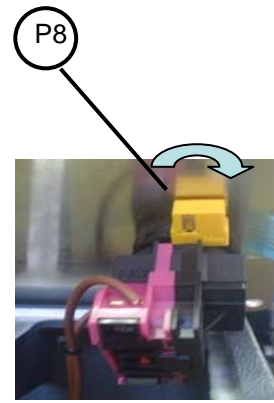

Fig.57

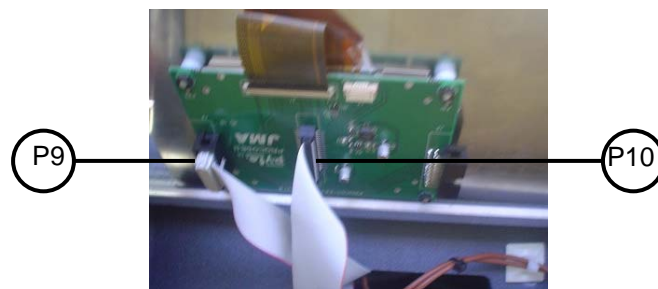

Fig.58

## 6.9 REPLACING THE LEDS

- 1) Turn the machine off at the main switch and disconnect the power cable.
- 2) Unscrew the 6 screws fastening the "rear motor casing". The screws are on the right and left sides, the upper and lower sections.
- 3) Release the two power strip cables (P11), by releasing the two screws (T29). (Fig.59)
- 4) Release the LEDS base, by unscrewing the two screws (T30). (Fig.58)
- 5) Release the two LED holders (P12) by unscrewing the two screws (T31). (Fig.59)
- 6) Replace and fasten the LEDS with both holders.
- 7) Screw in the LEDS base.
- 8) Finally connect the cables to the power strip.

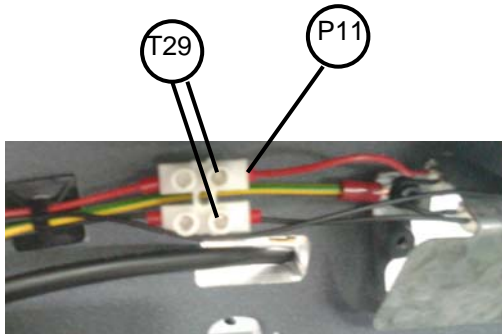

Fig.57

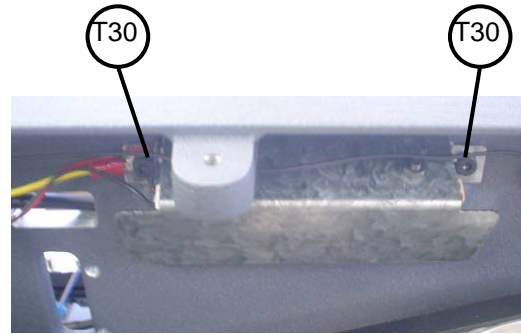

Fig.58

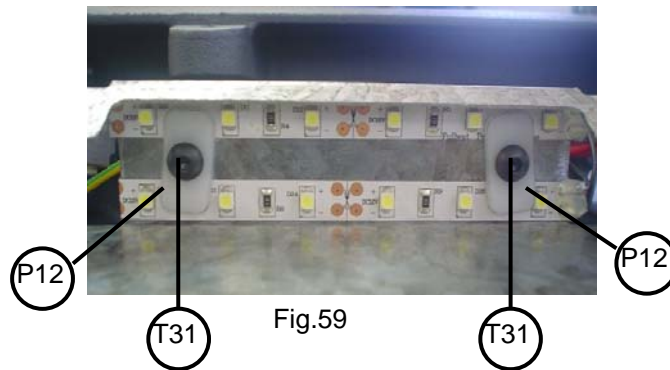

Fig.59

## 7 WASTE DISPOSAL

*Waste is understood to mean any substance or object produced by human or natural activity that has been or is to be thrown away.*

### 7.1 PACKAGING

- *As the packaging in which the AVANTCODE machine is supplied is cardboard, it can be recycled.*
- *It can only be disposed of in the special cardboard containers.*
- *The machine is protected with polymeric material that is equivalent to solid urban waste, which can therefore only be disposed in normal waste containers.*

### 7.2 SHAVINGS

- *The residue produced by cutting keys is classified as special waste, but it is equivalent to solid urban waste, for example a metal scourer.*
- *Such waste should be disposed in compliance with EU regulations, by being delivered to special waste disposal facilities.*

### **7.3 MACHINE**

- *The machine needs to be disabled prior to demolishing it, by cutting off the electricity supply and separating the plastic and metal parts.*
- *Once this separation has occurred, the waste elements can be disposed in accordance with the legislation of the country where the machine is used.*

## **8 SUPPORT**

*Alejandro Altuna provides technical support to all AVANTCODE machine customers.*

*To ensure complete operator and machine safety, any operations that are not described in this manual should only be performed by the manufacturer or technical support team. If you have any questions about using the machine, please contact the address specified on the back of the manual.*

## **9 CONSTITUENT PARTS**



